

TAC II SCADA System Installation Planning Guide

TAC II SCADA System Installation and Planning Guide

Copyright ©1992-2015
All Rights Reserved
Data Flow Systems, Inc.
605 N. John Rodes Blvd., Melbourne, FL 32934
Phone 321-259-5009 • Fax 321-259-4006

NOTICE

Data Flow Systems, Inc. assumes no responsibility for any errors that may appear in this document nor does it make any commitment to update the information contained herein. However, we welcome questions regarding the information contained in this document.

Data Flow Systems, Inc. also reserves the right to make changes to the TAC II RTU and its associated modules and to the information contained in this document at any time, without notice.

This document last revised July 11, 2015

TABLE OF CONTENTS

- Chapter 1: TAC II SCADA System Overview1**
- Purpose of This Guide..... 1
- SCADA System..... 1
- The TAC II SCADA System 2
- TAC II Communications..... 3
 - Communication Methods 3
 - Communication Protocols..... 4
- The Central Site and RTUs 5
 - Hyper SCADA Server 5
 - System Access..... 6
 - Central Terminal Unit (Master Radio) 7
 - Forwarding Terminal Unit (FTU) 7
 - The Remote Terminal Unit (RTU)..... 8

- Chapter 2: Function Modules and PLC Devices 11**
- Overview 11
 - Communication and Power Supply Modules 11
 - Digital Modules 11
 - Analog Modules..... 12
 - PLC Devices 12
- What Can I Monitor and Control?..... 12
 - Digital Inputs 12
 - Digital Outputs..... 12
 - Analog Inputs 13
 - Analog Outputs 13
 - Using the Information..... 13
- Descriptions of Function Modules and PLC Devices 14
 - Analog Control Module (ACM002) 15
 - Analog Monitor Module (AMM002) 16
 - Bus Extender Module (BEM001)..... 17
 - Digital Control Modules (DCM003-1 through -6) 18
 - Digital Monitor Module (DMM002)..... 20
 - Fiber Interface Module (FIM001) 21
 - Power Supply Module (PSM003-1) 22
 - Programmable Logical Control Module (PLC) 23
 - Radio Interface Module (RIM006) 27
 - RDP180-C (Cellular RTU)..... 28
 - Solar Power Module (SPM002)..... 29
 - Telemetry Control Unit (TCU001)..... 30
 - Telemetry Interface Module (TIM007)..... 31

- Chapter 3: Pre-Installation Planning33**
- Introduction..... 33
- Radio Frequencies and Licensing..... 33
 - Frequencies 33
 - Licensing..... 34

Table of Contents

Site Surveys	34
Central Site.....	34
Remote Sites	35
OSHA/Safety Issues	36
Confined Space Operations	36
Lockout / Tagout Procedures	36
Bloodborne Pathogens	37
Chapter 4: Central Site Installation	39
Introduction	39
Hyper SCADA Server & Primary Operator Workstation	39
The CTU and Central Antenna Tower.....	40
Connecting the Hyper SCADA Server to the CTU	40
Power Supply for the CTU	41
Chapter 5: Remote Site Installation	43
Introduction	43
Phase I: Antenna Tower Erection & Preliminary Site Work	43
Assemble Antenna and Tower	44
Set Antenna Tower.....	44
Mount Enclosure.....	44
Ground Tower & Align Antenna.....	45
Phase II: Conduit & Panel Work.....	45
Running Conduit	45
Phase III: Pulling Wire & Wiring I/O Points	46
Wiring the Power Supply Module.....	46
Wiring a Digital Monitor Point	47
Wiring a Digital Control Point	48
Wiring a Pulse Accumulator Point on a Digital Module (DCM/DMM)	49
Wiring an Analog Monitor Point	50
Wiring an Analog Control Point	52
Wiring the RTU Side.....	53
Wiring a Bus Extender Module (BEM)	55
Wiring a Solar Power Module (SPM)	57
Wiring the Control Panel Side	58
Chapter 6: Module Testing, Alignment & RTU Configuration.....	59
Test Wiring.....	59
Digital Monitor Test Card (DMTM001).....	59
Digital Control Test Card.....	59
Install Modules	59
Test VSWR.....	60
Align Antenna.....	60
Final Checkout of the RTU Site	60
Configuring the RTU into the Central Site.....	60
Chapter 7: RTU Input / Output (I/O) Sheets.....	63
Analog Control Module (ACM002)	63
Analog Monitor Module (AMM002)	64

Bus Extender Module (BEM).....	65
Digital Control Module (DCM003-1).....	66
Digital Control Module (DCM003-2).....	67
Digital Control Module (DCM003-3).....	68
Digital Control Module (DCM003-4).....	69
Digital Control Module (DCM003-5).....	70
Digital Control Module (DCM003-6).....	71
Digital Monitor Module (DMM002).....	72
Fiber Interface Module (FIM001).....	73
Power Supply Module (PSM003).....	74
Programmable Logical Control Module (PLC001).....	75
Programmable Logic Controller (PLC033).....	76
Pump Control Module (PCM001).....	77
Radio Interface Module (RIM006).....	78
Solar Power Module (SPM002).....	79
Telemetry Interface Module (TIM007).....	80
Telemetry Control UNIT (TCU001).....	81
Wire Color Abbreviation Chart.....	81

Index.....	83
-------------------	-----------

Table of Figures

Figure 1: Typical TAC II SCADA System.....	2
Figure 2: Modular Backplane.....	10
Figure 3: Modular Backplane Installed in 200 Series RTU.....	10
Figure 4: Printed Circuit Board.....	14
Figure 5: Analog Control Module.....	15
Figure 6: Analog Monitor Module.....	16
Figure 7: Typical BEM Installation.....	17
Figure 8: Bus Extender Module.....	17
Figure 9: Digital Control Module.....	19
Figure 10: Digital Monitor Module.....	20
Figure 11: Fiber Interface Module (View 1).....	21
Figure 12: Fiber Interface Module (View 2).....	21
Figure 13: Power Supply Module.....	22
Figure 14: PLC001.....	23
Figure 15: PLC033.....	25
Figure 16: Radio Interface Module (View 1).....	27
Figure 17: Radio Interface Module (View 2).....	27
Figure 18: RDP180-C (Cellular RTU).....	28
Figure 19: Solar Power Module.....	29
Figure 20: Telemetry Control Unit (TCU).....	30
Figure 21: Telemetry Interface Module.....	31
Figure 22: Typical Hyper SCADA Server System.....	40
Figure 23: Typical Antenna Tower Installation.....	43
Figure 24: Digital Monitor Module Wiring for Low Voltage Monitoring.....	47
Figure 25: Digital Monitor Module Wiring for High Voltage Monitoring.....	47
Figure 26: Digital Control Module Wiring.....	48
Figure 27: Digital Module Wiring (DCM/DMM) for 10-30V Pulse Accumulator Point.....	49

Table of Contents

Figure 28: Analog Monitor Point Wiring (0-20 mA Current with Transducer Supplied Power).....	50
Figure 29: Analog Monitor Point Wiring (0-20 mA Current with AMM-supplied Power)	51
Figure 30: Analog Monitor Point Wiring (0-5 Volt).....	51
Figure 31: Analog Control Point Wiring	52
Figure 32: Addressing Modules	54
Figure 33: Modular Backplane (MBP001) Used in RTU204	54
Figure 34: BEM Wiring (Standard Installation)	55
Figure 35: BEM Wiring (TCU Installation)	56
Figure 36: Solar Power Module Wiring	57

Chapter 1: TAC II SCADA System Overview

Purpose of This Guide

This guide outlines the planning considerations and installation techniques required for proper installation of a TAC II SCADA System. Additionally, it provides information that is helpful when initially planning and configuring a SCADA system.

The intended audience is DFS installation teams, DFS Authorized VARs, Engineering Firms and established DFS customers. This guide assumes the reader is an experienced electrical technician, who has similar systems or instrumentation experience and is familiar with electrical codes and safety procedures.

This text is not all inclusive of the products and services offered by DFS. The evolving needs of our customers and the creative nature of Data Flow Systems' engineering group ensure there is a continuous stream of solutions and products that may not be documented herein.

You can find brochures, technical specifications, and installation and operation manuals for Data Flow Systems' hardware and software products on our website (www.DataFlowSys.com).

Note: This manual references HT3 – the latest version of Data Flow Systems' SCADA software. However, most of the information also applies to HyperTAC II. Differences will be noted where they occur.

SCADA System

EPA and other government regulations have mandated that public utilities provide ever-increasing oversight of their systems. Utility departments are learning that a good SCADA system -- the technology of automatic transmission of data from a remote source to a receiving station for recording and analysis -- can provide the backbone for remotely monitoring and controlling their equipment and services.

Because a utility's stations are typically spread throughout a district, city, or county, SCADA systems are the most reliable and cost effective means to tie each of the remote locations back to the plant. When using radio, the system utilizes a common FCC licensed frequency, master radio and a central server with HMI computer(s). The server queries

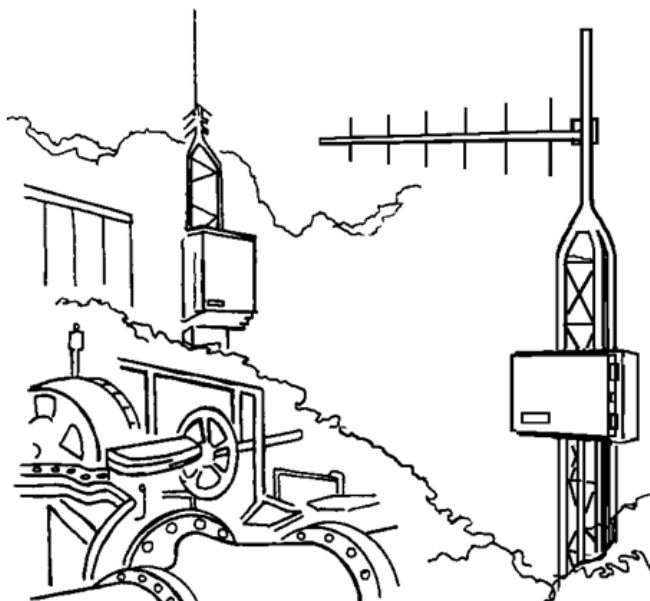

each of the remote locations for the status of pumps, valves, pressures, etc. The system can also provide remote control as well as local automation of each of those components and incorporate process automation functions.

The SCADA server polls each remote location (Remote Terminal Unit - RTU) for information. To do this, each RTU has a unique address so it knows when to respond. The total poll loop time is dependent on the number of remote sites within the system as well as the number of changes that occurred since the last response.

The TAC II SCADA System

A typical DFS TAC II SCADA System starts with the central site equipment, usually located at a treatment plant or main office. The equipment at the central site usually includes a SCADA master (CTU) with radio transceiver, a communications tower with antenna, a Hyper SCADA Server (HSS), and at least one HMI computer. Options for using Ethernet and cellular to communicate with remote sites are also available.

Remote Terminal Units (RTU) are located at the well-fields, lift stations, pump stations, treatment plants, reuse ponds, storage tanks, and other various operations scattered throughout a utility's service area and plants. I/O modules in the RTU are wired to the equipment that the utility wants to monitor and control.

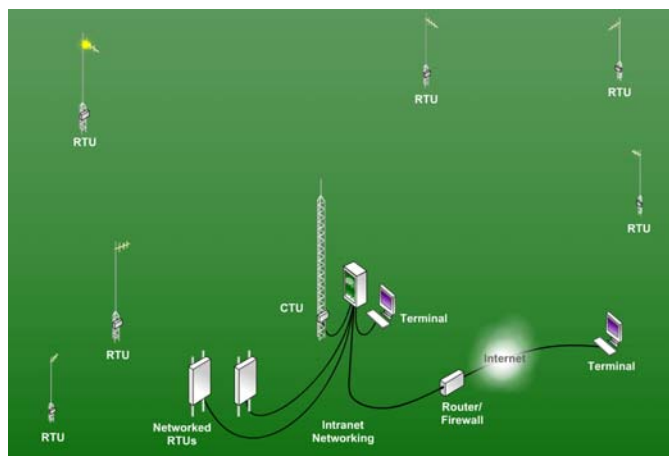

Figure 1: Typical TAC II SCADA System

The Hyper SCADA Server (HSS) controls the RTU polling sequence, collects data from remotes using radio, Ethernet network, and cellular network sources, stores the data in a MySQL database, and hosts the HT3 SCADA Software. The HSS makes the data available to users on the local network and to the Internet through a firewall.

The SCADA Master (CTU) communicates with most remotes directly. When that isn't possible, two options are available:

- A Forwarding Terminal Unit (FTU), aka "repeater," can extend the CTU's range to include a cluster of RTUs or utilize a tall antenna mounting location.
- A technique called digipeating, aka "store and forward," can be used to add one or two distant stations using an existing RTU to bridge the gap.

We designed the HT3 SCADA Software specifically for use by water and wastewater utilities. All of its features, functions, and reporting tools are the result of specific needs and recommendations received from our customers.

Data Flow Systems' goal was to build a total solution package designed specifically for the utility to easily operate, maintain, and expand. Each system is a mix of standardized, off-the-shelf components

configured to support the unique applications of each customer. We tailor the design to maintain a highly efficient, reliable, and cost-effective system.

TAC II Communications

The TAC II SCADA System offers multiple communication methods and protocols. DFS analyzes each utility's application to determine which implementation best suits their requirements.

The system transmits message information to the Hyper SCADA Server. This information is analyzed for alarm conditions, used to update instructions to other sites, and stored for use in detailed reports. Every transition of an I/O (input/output) point in the system is logged in the database, permitting the user to create reports and trends for any point in the system.

Communication Methods

The central site can communicate with remotes using radio, Ethernet, or cellular.

Radio

When radio communication is used, DFS' primary goal is to establish a direct radio link between the CTU and RTU. Our system employs an ingenious technique called "Continuous Differential Polling." Continuous Differential Polling is a time-division-multiplexed radio network that supports poll by exception and sequential global polling (multiple RTUs responding in sequence to a single poll). RTU messages incorporate time-tagging to provide a minimum time accuracy of +/- 2 seconds of the actual change at the RTU.

DFS exclusively uses FCC Licensed Frequencies in the VHF and UHF bands for their performance characteristics and licensing protections. We do not recommend the use of licensed/unlicensed 900 MHz frequencies or 2.4/5.8 GHz spread spectrum for SCADA communications.

The area of coverage varies due to terrain, antenna height, frequency band, and foliage. Data Flow Systems will provide a radio-link budget survey for your specific sites and locations to determine antenna height requirements. Chapter 4 has additional information on frequencies and licensing.

Radio RTUs come installed with either a Radio Interface Module (RIM) or Telemetry Interface Module (TIM).

- **Radio Interface Module (RIM006-X)** – The RIM incorporates an FM digital synthesized radio transceiver programmed to a customer-specific FCC licensed frequency. The RIM006 controls the radio during the polling sequence. All communications are in ASCII and utilize an error detecting data transfer protocol. The RIM006 features a service port that provides communications link monitoring locally. The service port also provides the capability to directly monitor and/or control each I/O module in its RTU.
- **Telemetry Interface Module (TIM007)** - The TIM is a microprocessor-controlled module with an integrated serial digital radio. The TIM is programmed to a customer-specific FCC licensed frequency. A data buffer on the TIM enables it to query its modules for status between radio polling loops and store that information until it is requested from the central site – a particularly

useful feature for sites with long radio polling loops. The TIM also features a wake up / report / sleep mode that aids in battery conservation in solar-powered applications.

Both the RIM and the TIM can interface with up to 15 I/O modules of any combination.

Both modules also support four levels of digipeating (store and forward). Digipeating enables the radio signal from a distant RTU to be routed to the central site by passing its message through up to three RTUs. This is a powerful option for RTU locations that require short antenna heights or those with distance or terrain challenges. Through this technique, the system can support a small number of remote stations outside the main coverage area without the utility having to acquire a second frequency or a repeater.

The DFS TAC II SCADA System as a whole can accommodate up to (505) RIMs or TIMs per communications link.

Ethernet

The SCADA System offers a means to communicate with RTUs over an Ethernet network connection. An RTU utilizing network for communications will incorporate the appropriate network appliance such as fiber media converter or Ethernet switch. 10 Mbps and 10/100 Mbps network speeds are supported, as well as multi-mode and single mode fiber optic connections. Fiber-based network communication is ideal when RTUs are located throughout a treatment plant.

Cellular

DFS offers a cellular RTU option for areas where a conventional radio-based SCADA system is not a viable option for monitoring remote sites. Instead of a radio, the RTU uses a Verizon cellular modem for communication. Using cellular networks and the Internet, the cellular RTU is able to provide around-the-clock delivery of data and information about your equipment.

Cellular RTUs use a pop-up scheme where the HSS operates as a “listener” via a special driver (Net DFP). Instead of polling the remotes, the HSS waits for messages from them. Each remote (Cellular RTU) stores status changes locally in an event table until one of four configured events occur. When an event occurs, the remote transmits information from the event table to the HSS, empties the event table, and begins accumulating event data again.

Communication Protocols

Our own highly efficient TAC II protocol provides time-tagging accuracy of two (2) seconds for changes in status occurring at each remote site. This level of accuracy is very important when dealing with how long a pump has run, or to determine exactly when a valve opened or an alarm condition occurred.

TAC II protocol maximizes data collection efficiency by only sending information that has changed. Once the driver in HT3 has obtained the status of a station it will begin to poll it for changes as opposed to requesting full status. For added efficiency the driver will poll groups of stations configured consecutively (up to 12) for changes.

With our Derivative Fractional Protocol (DFP), HT3 doesn't send change/no change queries to remotes, but instead polls them for table information. In this mode, the overhead of asking for changes and then polling for status is eliminated. Stations equipped with appropriate Telemetry Interface Modules (TIMs)

or Telemetry Control Modules (TCUs) can use DFP. DFP also has a solar mode, which is used for all solar powered sites.

A third communication protocol (NetDFP) is used for cellular stations. NetDFP is essentially a Modbus driver with a special flag set in the HT3 registry that causes the driver to operate as a "listener." The cellular RTUs communicate over the Verizon cellular network using a pop-up scheme.

Our HT3 SCADA Software also supports Modbus TCP/IP, Modbus RTU, and Modbus ASCII.

The Central Site and RTUs

The central site equipment consists of a Hyper SCADA Server, Central Terminal Unit (for radio communication), and one or more HMI (human-machine interface) computers.

Hyper SCADA Server

The Hyper SCADA Server (HSS) is a self-contained, modularized, SCADA Server that is packaged in a protective wall-mounted enclosure. The HSS controls the RTU polling sequence, collects and stores data, and hosts the HT3 SCADA Software for all available user access methods (e.g., computer workstations on the local network, smart phones over the Internet). The Hyper SCADA Server couples the power of networking with the stability and versatility of the Linux Operating System and MySQL to offer a SCADA System Server that is secure, fast, and reliable.

The Hyper SCADA Server includes all of the necessary software required to implement a fully operational SCADA System right out of the box. It includes DFS' HT3 SCADA Software Program, Browser-based Client HMI Software, a virtually unlimited number of Development Client Licenses, Alarm, Report and Trending Software, Process Logic Building Software, Graphical Screen Building Tools, Historical Database and MySQL.

We designed the HT3 SCADA Software specifically for use by water and wastewater utilities. All of its features, functions, and reporting tools are the result of specific needs and recommendations received from our customers.



A fiber optic connection is established to communicate with the master radio (where applicable). Also connected are printers, LAN networks, remote terminals, and any other computer equipment and software required to support the utility's SCADA requirements.

For cellular operation, the HSS must have a static IP address and be available on the Internet. When your HSS is installed by DFS, it will be configured with the firewall modified to open a specific port. This is the port the HSS will be "listening" on for messages from the Cellular RTUs.

The system can be partitioned so the fresh water, wastewater, and/or collections departments can simulate having their own system. This, in effect, allows the utility to operate separate systems on the same frequency using the same central site equipment.

It is important to note that the operation of the utility's equipment at the remote sites is not directly dependent on the system. The utility's equipment at a remote site will continue to operate in the event of a communications or central site failure. Naturally, data logging and alarm annunciation are limited during these types of failures.

Equipment operations at critical, but isolated, remote sites can also be controlled by installing "intelligent" PLC modules at the site. These modules contain preprogrammed logic and firmware instructions or parameters written to the customer's specification. During normal operations, the parameters (set points) can be changed or updated remotely by the SCADA system over the communications link and locally at the PLC.

System Access

Operator Workstations

Operator workstations (HMI computers) access the system over the local network and the Internet. Our HMI is browser based and provides easy access to the SCADA system. Multiple users can simultaneously monitor, control, view alarms, and run reports and trends.



HT3 Mobile

A mobile version of HT3 optimized for today's smart phones is available as an upgrade to your system. In HT3 Mobile, users will find all the essential tools needed for working in the field.

Remote Maintenance Access (411)

DFS service personnel can remotely access the utility's system for maintenance and trouble shooting via a customer-provided secure VPN connection. This is a powerful and responsive tool to help the utility diagnose problems and train operators. Additionally, we can easily download SCADA software updates (always free), and modify or correct equipment configurations over the maintenance modem.

Alarm Dial-Out (911)

If an alarm signal from a remote site is not acknowledged at the Central Site, the system will begin calling a customer configured phone list.

Once someone answers the phone, the system will ask for an authentication code before announcing the alarm condition. The system will continue to dial down the list until it gets a correct code response. The functionality of this feature is completely configurable by the user. The system records all voice unit activity in the system log.

Telephone Line (for alarm dial out feature)

We recommend the use of one (1) separate telephone line at the Hyper SCADA Server location for independent use of the 911 feature.

Central Terminal Unit (Master Radio)

The Central Terminal Unit (CTU) houses the master radio and communicates with the RTUs. Fiber optic cable connects the CTU to the Hyper SCADA Server while providing electrical isolation for protection from surge and lightning damage. The CTU is typically mounted on the central site communications tower.

DFS designs the radio system specific to your required coverage area. The CTU antenna tower height is dictated by the radio communications study. The central antenna is typically a high gain, omnidirectional antenna selected specifically for the frequency of operation.

The data transmission connection between the Hyper SCADA Server and the CTU is by fiber optic cable. DFS incorporated optical fiber connections as its standard in order to isolate the server from high voltage spikes induced by nearby lightning strikes. This network connectivity also provides for another design tool in the system architecture, as there is no requirement for the HSS to be co-located with the CTU and tower.

The radio and power supply modules used at the CTU and RTUs are the same, and are interchangeable throughout the system. This provides for increased redundancy, and reduces the spare parts requirements.

Forwarding Terminal Unit (FTU)

The FTU provides a means to establish communications to a network of RTUs that are distant from the master radio or are otherwise unable to communicate due to terrain. The FTU is similar to a repeater and incorporates two radios.

The FTU utilizes one frequency for receiving and transmitting communications with the master radio, and another frequency for communicating with the RTUs. This difference permits RTUs to act as digipeaters since they receive and transmit on the same frequency. Continuous Differential Polling is utilized and RTU messaging incorporates the same +/- 2 seconds time-tagging accuracy as the standard system.

The Remote Terminal Unit (RTU)

Remote Terminal Units (RTU) are located at the well-fields, lift stations, pump stations, treatment plants, reuse ponds, storage tanks, and other various operations scattered throughout a utility's service area and plants.

I/O modules in the RTU are wired to the equipment that the utility wants to monitor and control. RTUs can communicate with the central site using radio, Ethernet network, or cellular network.

Radio-based RTU

Most radio-based RTU installations incorporate an Enclosure, Tower Assembly, and Yagi Antenna. Shown at right is an example of a typical assembly.

- The antenna shown is a high gain Yagi.
- The mast is a 21 foot galvanized 1¼" pipe and the tower is a Rohn top section encased in a concrete foundation.

DFS has several RTU antenna tower configurations, including assemblies certified to meet various wind load requirements.

The RTU is "wired" into the motor control circuits and signaling circuits within the station's control panel. It communicates with the central site via a two-way radio link. The central sequentially polls each RTU to receive status from, or transmit instructions to, the attached equipment. The total poll loop time is dependent on the number of remote sites within the system as well as the number of changes that occurred since the last response.

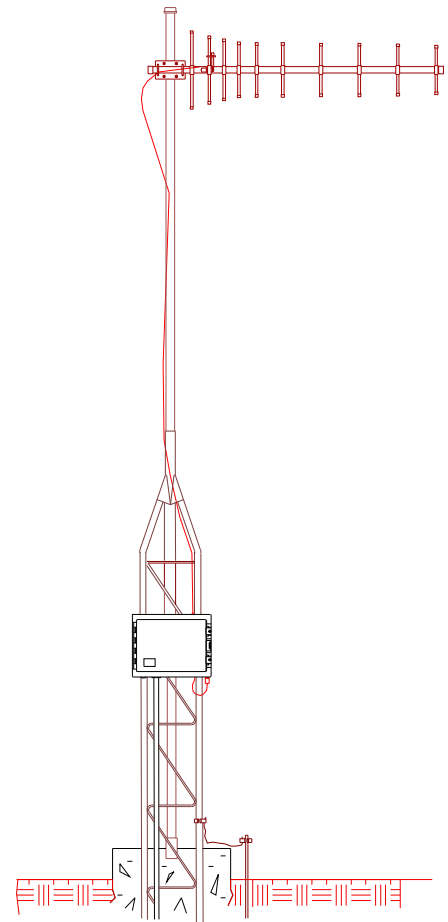

Ethernet-based RTU

This is typically used in an in-plant RTU that would otherwise require a "rubber duck" antenna. Using a network interface module in place of a RIM and antenna greatly reduces polling time.

Each RTU station contains a network module - either a NIM (Network Interface Module) or a FIM (Fiber Interface Module) that is installed in the Radio Interface Module (RIM) slot of the RTU. The network module in each RTU transfers information between the Hyper SCADA Server and its resident modules. No connector changes are necessary; the FIM and the RIM are keyed the same.

Communication between the HSS and the RTU's function modules takes place over a network via a NIM driver; the Network RTUs and the HSS must be on the same local area network.

The FIM supports both 9600 and 1200 bps modules. To obtain the most efficient polling rate, we recommend that 9600-baud modules be used.

Cellular-based RTU (RDP180-C)

A Cellular SCADA System is particularly useful for a utility or company with an extended service area where a conventional radio-based SCADA system is not a viable option for monitoring remote

sites. Instead of a radio, the RDP180-C RTU comes installed with an RDP180 (a rail-mounted PLC) that uses a Verizon cellular modem for communication.

The RDP180-C features a NEMA 4X-rated, non-metallic enclosure, RDP180, power supply (includes 10A breaker), 1.2Ah backup battery, and cellular antenna. The RDP180 provides nine (9) discrete inputs (interposing relay), two (2) discrete outputs (dry contact), and one (1) analog input (0-5VDC or 4-20A) as local I/O. (I/O expansion is possible with the installation of additional equipment.)

Each Cellular RTU provides time stamped status of selected data point that is accurate to the second. This I/O as well as built-in Special Function Registers, which include such things as cell signal strength and power supply voltage, can be configured to report changes in status to the HSS.

A cellular RTU requires a Verizon data plan, Hyper SCADA Server with HT3 3.1.1 or newer installed, and a Hyper SCADA Server with a static IP address that is accessible via the Internet

RTU Enclosures

DFS fabricates its RTU enclosures from high-grade stainless steel. They are “rain tight,” “weatherproof,” and can be installed in “damp and wet locations” as defined in the National Electrical Code (NEC).

The white painted exterior is not to protect the metal; rather, its purpose is to help keep the interior cooler by reflecting heat.

All fittings, mounts, brackets, latches, nuts and bolts used in fabricating and mounting the enclosure are stainless steel. All other components are hot-dipped galvanized or otherwise certified for outdoor and electrical use.

The size of an RTU enclosure is determined by the number of active modules required for the application. Each RTU contains a power supply module, a radio or network module, and up to 2, 4, 10, or 15 input/output modules. Each module is a separate, plug-in, functional unit that makes service and repair very easy and eliminates the need for tools.

The 200 Series RTU Modular Backplane

The plug-in function modules used in the 200 Series RTUs are plugged into card edge connectors mounted on a passive Modular Backplane (MBP). The MBP is a printed circuit board composed of card edge connectors for the modules, module bus circuitry, and a connection for the back-up battery.

The MBP bolts into the RTU enclosure, serving as both a motherboard and backplate onto which the active modules are plugged. Wiring connections made to terminals are permanently soldered on the backplane - meaning, the plug-in module can be removed from the MBP without disturbing the wiring or requiring the use of tools. There are no active components permanently mounted to it, making it highly reliable. (See photo on next page.)

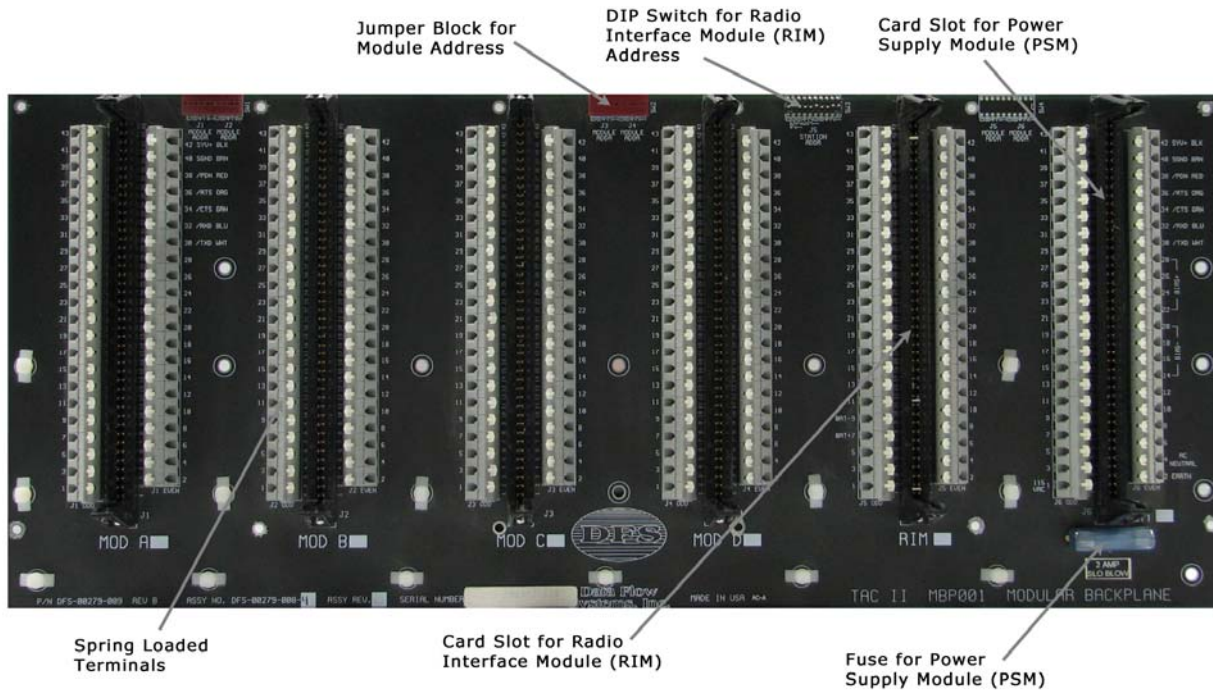

Figure 2: Modular Backplane



Figure 3: Modular Backplane Installed in 200 Series RTU

Chapter 2: Function Modules and PLC Devices

Overview

Each function module and PLC device is a separate, self-contained device. All of the modules listed below except the Telemetry Control Unit (TCU) and the Rail Data Processor (RDP180) are plug-in function modules.

The plug-in function modules are designed to be installed in a slot of the Modular Backplane (MBP). This design allows them to be removed without disturbing field wiring. The base of each function module is a 5" x 7" printed circuit board (PCB). The PCB contains all of the hardware and firmware required to provide the specific functions for which we designed the module to perform.

The Telemetry Control Unit (TCU) is designed to be permanently installed in a panel using mounting brackets supplied by DFS. The unit can be mounted flush to the back plate of the panel, stood off the back plate, or mounted to a front panel. The TCU can be incorporated into a Remote Terminal Unit (RTU) by using a Bus Extender Module (BEM). The RDP180-C is designed as a standard DIN-rail mounted device.

All CTUs and 200 Series RTUs contain the Power Supply Module and a communications module (radio or Ethernet). All other modules are dictated by the application, as their use depends on what equipment the utility wants to monitor and/or control at the site.

Function modules can be mixed and matched as the application requires and in no particular order (ease of expansion). Adding an I/O module to expand an existing RTU is as simple as plugging it in, wiring it up, and updating the configuration in the SCADA Server.

The following types of function modules and PLC devices are available:

Communication and Power Supply Modules

- Power Supply Module (PSM003-1)
- Solar Power Module (SPM002)
- Telemetry Interface Module (TIM007)
- Radio Interface Module (RIM006-X)
- Network Interface Module (NIM001 - ten different versions are available)
- Bus Extender Module (BEM001)

Digital Modules

Modules with I/O points having only two states (e.g., On/Off, Open/Closed, etc.)

- Digital Monitor Module (DMM002)
- Digital Control Module (DCM003-X - 6 versions available) – Also features digital input capabilities.

Analog Modules

Modules with I/O points represented as a numerical value (e.g. pressure, level, etc.)

- Analog Monitor Module (AMM002)
- Analog Control Module (ACM002) – Also features digital input capabilities.

PLC Devices

Devices that perform complete, automatic control functions.

- Programmable Logical Control Module (PLC001 and PLC033) – Both of these PLCs are designed as plug-in function modules. They can monitor and control remote site equipment locally on a stand-alone basis.
- Telemetry Control Unit (TCU001) – Pump controller designed to automate the operation of simplex, duplex and triplex sewer pumping stations. It is also customizable for Variable Frequency Drive (VFD) applications.
- Rail Data Processor (RDP180) – Rail-mounted PLC used in cellular RTUs.

What Can I Monitor and Control?

Deciding what the utility should monitor and control is one of the most important aspects of setting up a SCADA system.

The function modules can monitor and control the following kinds of I/O (input/output) points and signals within the utility's system.

Digital Inputs

Digital inputs (DI) monitor a voltage/no voltage condition. Examples of DI monitoring points include:

- pump runs and motor starter failures
- commercial power loss
- floats used to indicate high/low well levels
- seal leaks
- generator running status
- valves open or closed
- intrusion alarms
- any other equipment or device whose operation opens or closes a circuit

Digital Outputs

Digital outputs (DO) can be used to control relays, actuators, motor starters, solenoid valves, etc. Examples of DO control points include:

- energize a relay
- activate or turn-off a motor starter circuit
- turn-on or off a remote generator
- open or close a valve

Analog Inputs

Analog inputs (AI) monitor devices that have an output of 0-5 VDC, or 0-20 mA. The Analog Monitor Module incorporates an isolated 24 VDC loop power source for each analog input point. Examples of AI monitoring points include:

- measuring pressure
- measuring flow
- measuring level
- measuring VFD speeds
- monitoring chemical analyzers

Analog Outputs

Analog outputs (AO) control devices that require 0-20 mA. The Analog Control Module incorporates an isolated 24 VDC loop power source for each analog output point. Examples of AO control points include:

- control a throttle valve
- control quantity of chemical injections
- control gates
- control VFD speeds
- display level or flow measured at a different location

Using the Information

Once the module's signals are transmitted to the central site, the SCADA system can do several things:

- Analyze the information to see if it matches pre-set alarm conditions, e.g., a loss-of-commercial-power alarm followed by a high-well alarm means send out the generator truck!
- Log the information into the history files used to produce management reports, e.g., a day-by-day report of run times by each pump at each site; or derived flow reports.

Using a mixture of function modules, any remote site can be configured to perform a broad range of digital and analog monitoring and control operations.

The following are additional considerations when planning the monitoring of I/O points:

- Do not focus on just monitoring alarm lights and bells. Instead, monitor the actual conditions that could cause the alarms to activate.
- A lot of information can be gathered just by analyzing pump run times rather than adding extra analog values such as amperage, head pressure or flow rate.
- Monitoring points that give you warnings of failure (e.g., sump floats, commercial power feeds, etc.) are imperative for timely responses to potentially damaging events.

Descriptions of Function Modules and PLC Devices

The following pages contain descriptions of the functions and capabilities of DFS' function modules. Cut sheets and specifications are available on our web site: www.DataFlowSys.com.

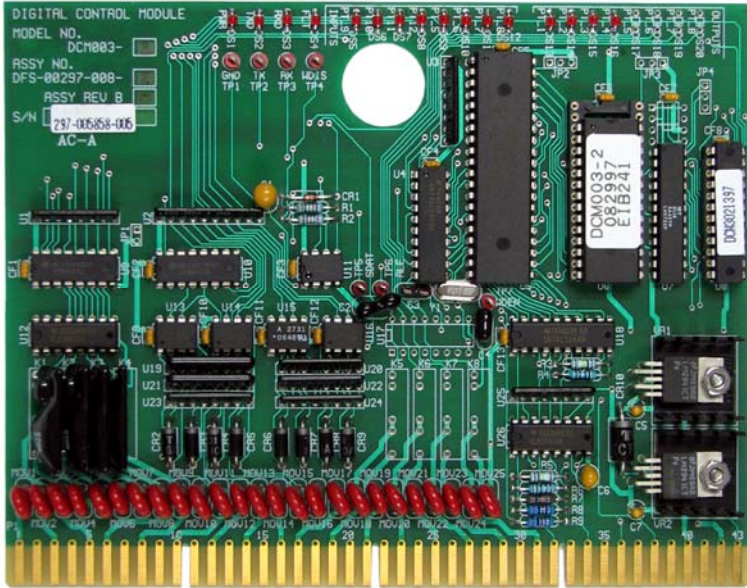

Figure 4: Printed Circuit Board

The following features are common to all of our function modules:

- Opto-isolated inputs and outputs.
- LEDs to indicate operating statuses and help with system diagnostics.
- Protective coatings on the circuit boards to help prevent corrosion.
- Each module is uniquely keyed. The card edge connectors are keyed to correspond with the assigned module to prevent inserting the wrong module into the connector.
- Gold edge connector fingers on the modules to ensure positive contact when plugged into the card edge connector mounted on the modular backplane.
- Non-destructive surge protection. Three-year warranty including lightning damage.
- No adjustments, switches, or straps. Modules are self-configuring.
- On-board communications and functional firmware.

Analog Control Module (ACM002)

The Analog Control Module (ACM) is a microprocessor-controlled multiple-output module used to control from one (1) to four (4) analog outputs. Each output provides 0-20 mA with 12-bit accuracy. The rate of change (slew rate) of each point is configured over the radio link.

An analog monitor point – at the same RTU or at any other TAC II RTU – can automatically control any of the ACM's outputs. This is configured at the central site computer and is available for an unlimited number of control points.

Typical Applications

- Pump Speed Control
- Valve Position Control
- Gate Position Control
- Flow Control
- Pressure Control
- Level Control
- Chemical Injection Control
- Remote Set-Point Control

LEDs

The ACM has status LEDs for:

- Power (PWR)
- Receive data (RXD)
- Transmit data (TXD)
- CPU fault (FLT)

I/O

An I/O listing for the ACM is on page 63.

Wiring

“Wiring an Analog Control Point” on page 52.

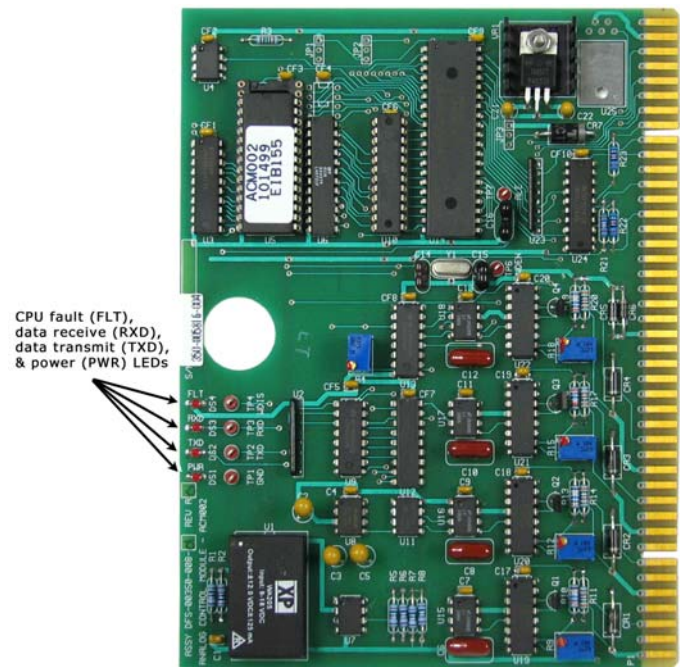

Figure 5: Analog Control Module

Analog Monitor Module (AMM002)

The Analog Monitor Module (AMM) is a microprocessor-controlled multiple-input card used to monitor from one (1) to four (4) analog inputs. The inputs are optically isolated; each input can be configured from 0-20 mA or 0-5V. This module can also monitor four (4) optically isolated digital inputs. The alarm limits (upper and lower) and the reporting dead-band are configured over the communications link by the central site.

Typical Applications

- Level Sensor
- Pressure Transducer
- Flow Meter
- Valve Position
- Gate Position
- Pump Speed
- Pump Current / Amperage
- Chemical Scale
- Chemical Analyzer
- Generator Fuel Level

LEDs

The AMM has status LEDs for:

- Power (PWR)
- Receive data (RXD)
- Transmit data (TXD)
- CPU fault (FLT)
- Status of each digital qualifier input point (QLF1, QLF2, QLF3, QLF4)

I/O

An I/O listing for the AMM is on page 64.

Wiring

- “Wiring an Analog Monitor Point,” page 50.
- “Wiring a Digital Monitor Point,” page 47.

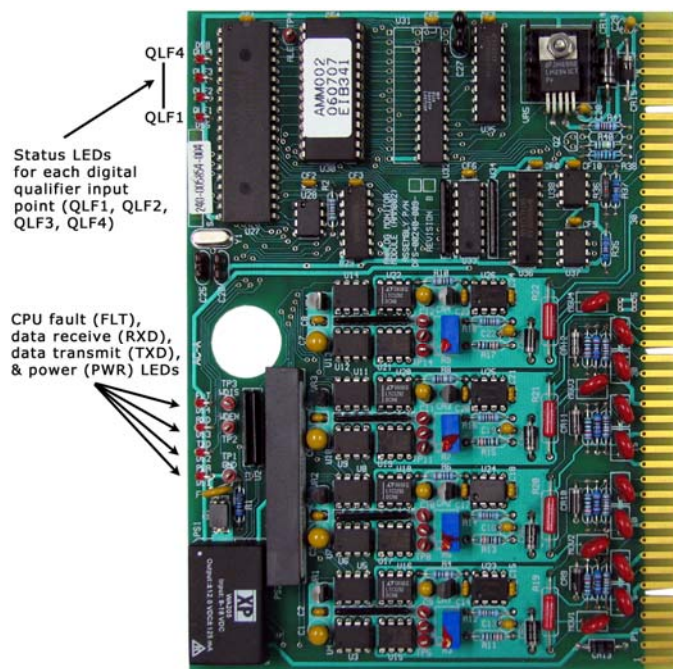

Figure 6: Analog Monitor Module

Bus Extender Module (BEM001)

The Bus Extender Module is used to remotely locate I/O modules or a TCU from an RTU that contains the communication modules. This provides versatility when expanding I/O at a site.

Typical Applications

- Expand I/O at a site by combining two (2) Remote Terminal Units (RTUs) into one logical unit that communicates through a single radio.
- Incorporate a TAC Pack Telemetry Control Unit (TCU) into a Remote Terminal Unit (RTU).

Typical BEM Installation

A six pair cable of up to 1000 feet connects the two BEMs. Once wired, all modules at both RTUs communicate to the central site via one RIM module. A communications-monitor-only port is provided to verify valid communications.

Connecting Two RTUs

- Two BEMs are required: one mounted next to the equipment, and another with the RIM mounted remotely.

Connecting a TCU to an RTU

- Only one BEM is needed for the RTU. The TCU has a built-in BEM adapter. When used in this configuration, the communication module must reside in the RTU.

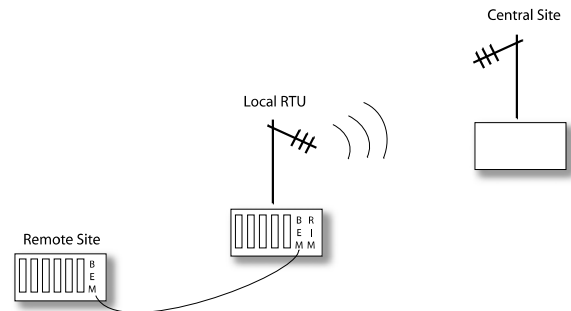

Figure 7: Typical BEM Installation

LEDs

The BEM has status LEDs for:

- Power (PWR)
- Receive data (RXD)
- Transmit data (TXD)

I/O

An I/O listing for the BEM is on page 65.

Wiring

“Wiring a Bus Extender Module (BEM),” page 55.

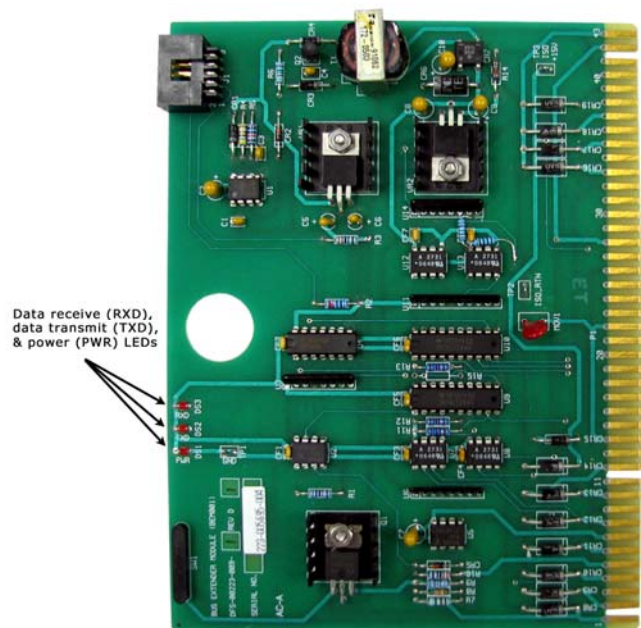

Figure 8: Bus Extender Module

Digital Control Modules (DCM003-1 through -6)

The Digital Control Module (DCM) is a microprocessor-controlled multiple input/output module that provides remote control of four (4) or eight (8) independent 60 to 280 volt AC devices (see Table 1). The control relays are available as solid state or mechanical relay contacts.

The DCM can also accept either four (4) or eight (8) digital inputs of 12 to 30 volt AC or DC (see Table 1). Voltages greater than 30 volts and up to 300 volts can be accommodated using an inline series resistor. All inputs have surge protection and opto-isolators to increase protection. Status reporting of the input points has an accuracy of two (2) seconds.

Additionally, the DCM is capable of monitoring pulse inputs such as those produced by a tipping bucket rain gauge. Up to four (4) digital inputs on the DCM003-1, -3, and -5 and up to eight (8) digital inputs on the DCM003-2, -4, and -6 can be configured to accept pulse inputs. When configuring pulse inputs, be aware that HT3 expects a module's pulse inputs to be contiguous beginning with the last point on the module (point 12). For example, in order for HT3 to poll three (3) pulse inputs on a DCM003, you must configure points 12, 11, and 10 on the module as digital pulse (DP) points.

Table 1: Digital Control Module (DCM003) Options

Part Number	Inputs	Outputs	Relay Type
DCM003-1	4	8 AC	Solid State
DCM003-2	8	4 AC	Solid State
DCM003-3	4	8 DC/AC	Mechanical
DCM003-4	8	4 DC/AC	Mechanical
DCM003-5	4	8 DC	Solid State
DCM003-6	8	4 DC	Solid State

Typical Applications

- Pump Control
- Valve Control
- Gate Control
- Clarifier Rake Control
- Aerator Control
- Generator Control
- Blower Control
- Remote Status Indication
- Pump Disable
- Station Disable
- Bar Screen Control
- Conveyor System Control
- Grit Auger Control
- Exhaust Fan Control
- Headworks Grit Cycle Control

LEDs

The DCM has status LEDs for:

- Power (PWR)
- Receive data (RXD)
- Transmit data (TXD)
- CPU fault (FLT)
- Status of each input/output point (PT_1, PT_2, PT_3, etc). LEDs are organized in sections labeled as INPUTS or OUTPUTS.

I/O

I/O listings for all DCM models are on pages 66-71

Wiring

- “Wiring a Digital Monitor Point,” page 47
- “Wiring a Digital Control Point,” page 48.
- “Wiring a Pulse Accumulator Point on a Digital Module (DCM/DMM),” page 49.

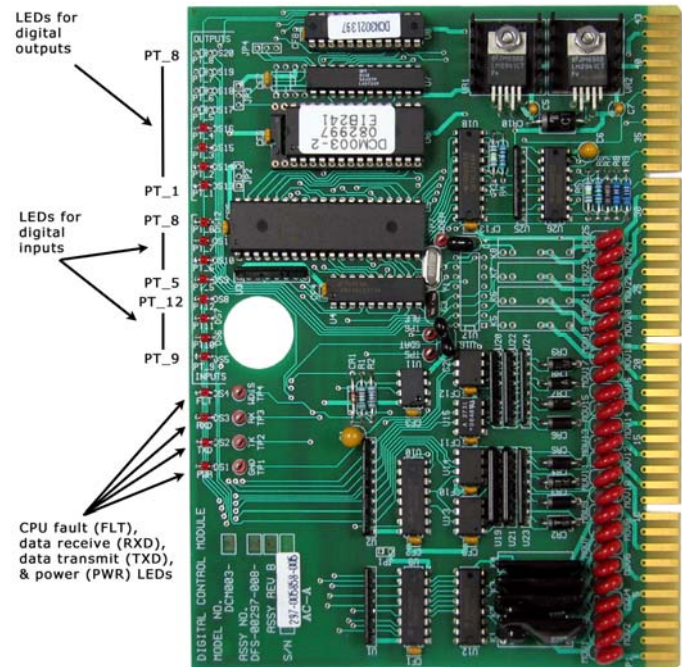

Figure 9: Digital Control Module

Fiber Interface Module (FIM001)

The Fiber Interface Module (FIM) is used in the Central Terminal Unit (CTU) and 200 Series RTUs.

The FIM is a network-interface platform for use with TAC II telemetry systems. It functions as an interface between a 10 or 10/100 Base-T Ethernet network and up to fifteen (15) function modules of any combination. The FIM's Ethernet media converter, which protects the unit from transient voltage damage, is available in 10 Mbps and

10/100 Mbps speeds and can be ordered with support for either multi-mode or single mode fiber.



Figure 11: Fiber Interface Module (View 1)

Typical Applications

- In a CTU, the FIM uses “serial tunneling” to convert the RIM's serial TTL (radio) data into network data for transmission over fiber optic cable to the Hyper SCADA Server.
- In a 200 Series RTU, the FIM replaces the RIM; communications with the central site are network based. The FIM will interface with up to 15 I/O modules of any combination.

LEDs

The FIM has status LEDs for:

- Power (PWR)
- Receive data (RXD1)
- Transmit data (TXD1)
- Serial port 2 (COM2)
- CPU fault (FLT)
- Test mode (TST)
- Network link and network traffic LEDs are on the FIM's media converter

I/O

An I/O listing for the FIM is on page 73.

Wiring

Refer to the *Network Interface & Distribution Modules Installation and Operation Manual*, which is available for download from the DFS website (www.DataFlowSys.com)

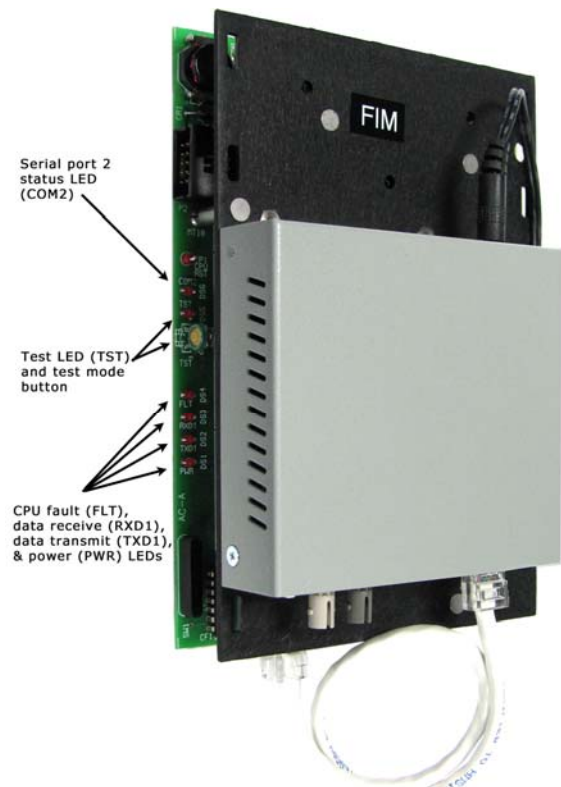

Figure 12: Fiber Interface Module (View 2)

Power Supply Module (PSM003-1)

The Power Supply Module (PSM) provides highly efficient conversion of 115 VAC power to 13.8 VDC power. The same model PSM is used in every Hyper SCADA Server (HSS), Central Terminal Unit (CTU), and 200 Series RTU.

The PSM features an isolated, unregulated +24V output for biasing up to 24 digital or six (6) analog input points. This output also provides for charging of the 12V backup battery co-located in the same enclosure, and supports the RIM interface for shutdown and power fail detect.

LEDs

The PSM has status LEDs for:

- Power
- Bias
- Shutdown

I/O

An I/O listing for the PSM is on page 74.

Wiring

“Wiring the Power Supply Module,” page 46.



Figure 13: Power Supply Module

Programmable Logical Control Module (PLC)

A DFS Programmable Logic Controller (PLC) can provide local site automation, as well as local Graphical User Interfaces (GUI)/Human Machine Interfaces (HMI). The architecture of the 200 Series RTU provides a simple and convenient platform for remote monitor and remote manual control using the I/O modules mentioned above without the use of any specialized programming at the remote site. When operations that are more complex are required at an RTU location, the addition of a PLC will permit monitor and control to operate at a completely new level of performance. Any 200 Series RTU can be designed to accept a DFS PLC module. A PLC can be added to an existing RTU through an upgrade process.

The DFS PLC line up includes the PLC001 and the PLC033 - both designed for direct installation into a modular backplane (MBP). Both PLCs come ready to take on the many diverse challenges that an application may require.

PLC001

The PLC001 is a robust PLC that uses Industrial Basic-52 as the programming medium. The PLC001 comes very capable of performing the essential services required of it: telemetry operations, local automation, PLC Central and communications interpreter. The hardware features include a communications port for serial communications and three service ports for monitoring operations and communicating with the radio and modules.

The PLC is wired into an RTU between the Radio Interface Module (RIM) and up to 15 other modules. It automatically communicates with the modules, getting their status and updating their outputs according to the application program. It communicates with the TACII central computer via the RIM, relaying status and control information. It also simulates virtual analog and digital modules to allow PLC program interaction with the telemetry system.

Typical Applications

- Quadruplex pump control station
- Analog-to-trip point conversion
- Pressure controller
- Land spreading system controller
- Reuse irrigation system controller
- Tank level controller
- Time of day & day of week control
- Variable Speed Pump Control

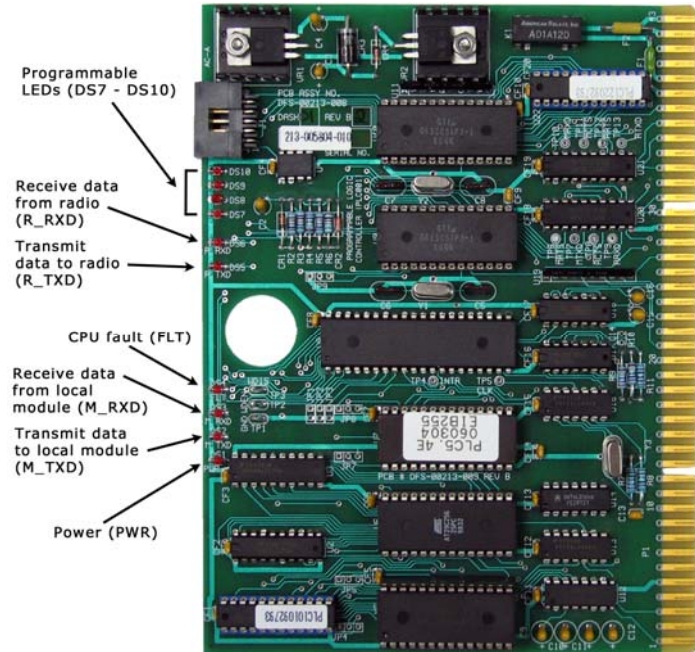

Figure 14: PLC001

Features

- Industrial BASIC programmable
- Program stored in Non-Volatile memory
- On-board editor
- Surge protected (nondestructive)
- LEDs on power, transmit data, CPU failure, and test
- On-board communications and functional firmware
- On-board voltage regulation
- Automatically retrieves data from modules on RTU bus
-
- Module is removable without disturbing field wiring
- Keyed to prevent damage
- Time-tagged messages
- Battery-backed clock/calander synchronized by telemetry
- Watchdog timer
- Gold edge connector fingers
- 1200 or 9600 baud communication
- UL Listed
- No on-board adjustments, switches or straps (selfconfiguring)

LEDs

The PLC001 has status LEDS for:

- Power (PWR)
- Transmit data to local module (M_TXD)
- Receive data from local module (M_RXD)
- CPU fault (FLT)
- Transmit data to radio (R_TXD)
- Receive data from radio (R_RXD)
- Four programmable LEDs (DS7, DS8, DS9, DS10) used primarily by the programmer to help with debugging programs and troubleshooting operations in the field.

I/O

An I/O listing for the PLC001 is on page 75.

Wiring and Programming

Refer to the *PLC001/SCU001 Operations Guide and DFS BASIC-52 Reference*, which is available for download from the DFS website (www.DataFlowSys.com)

PLC033

The PLC033 is the new standard for DFS automation and control, and fits into the architecture in the same fashion as the PLC001 - but better. The PLC033 is a microprocessor-controlled programmable logic controller designed for implementing local logical control at the RTU. Designed for the new millennium, the PLC033 includes the features needed for today's operational requirements: Industrial Ethernet, full Linux core processing, RS-232, RS-485, full Modbus support, and ladder logic programming. The PLC033 coupled with the provided Process Management Tool (PMT) is a versatile that provides the front-end functionality required for operators to control and monitor their processes in today's industrial environment.

The PLC033's Ethernet port and serial port (either RS-232 or RS-485) can be used to expand the PLC033's functionality. In addition to being the PLC033's programming interface, the on-board Ethernet port enables the PLC033 to function as a network slave device using either DFS NIM RTU protocol or Modbus TCP protocol. The PLC033's serial port enables it to function as a Modbus RTU/ASCII master or slave device. Optionally, the PLC033 can function as a PLC central enabling it to poll remote DFS RTUs in addition to local modules and Modbus-compatible I/O.

For more information on the PLC033, refer to the *PLC033 Installation and Operation Manual*, which is available for download from the DFS website (www.DataFlowSys.com)

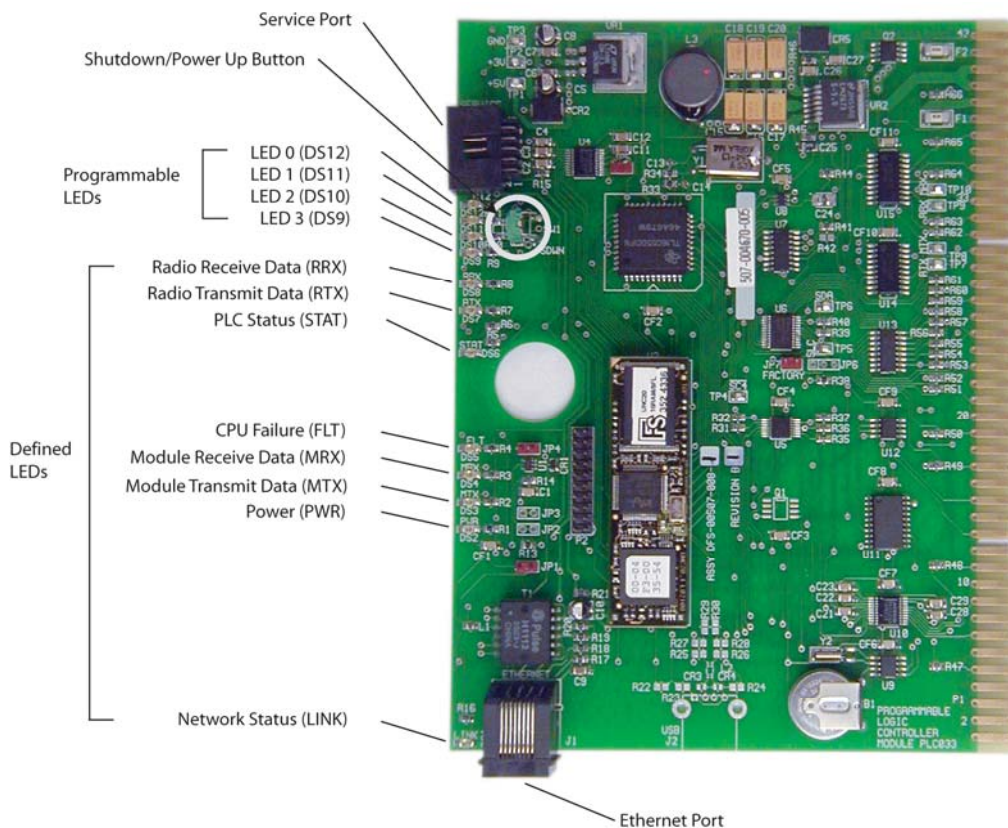

Figure 15: PLC033

Features

- Ladder Logic Programming
- Process Management Toolkit (PMT) software included with product
- Communication and I/O parameters configured with user-friendly interface (I/O Builder)
- Modbus TCP and DFS NIM RTU-based communications via Ethernet interface
- Custom status and control screens can be created using supplied software (Screen Builder)
- Communicates with master/slave devices via serial port, which can be used as RS-232 or RS-485
- 33 MIP ARM processor with 8M of Flash ROM and 16M of RAM
- 1200 or 9600 baud communications with TAC II devices
- Up to 38.4 Kbps with external RS-232/RS-485 devices using Modbus RTU or ASCII protocol
- Program stored in non-volatile memory
- Real time clock for time of day functions
- 4 programmable LEDs and 8 hardware/firmware-controlled LEDs
- Monitors its own power source and saves accumulated data when a power failure is detected
- Shutdown button enables graceful shutdown of all PLC033 processes
- Surge protected (nondestructive)
- On-board communications and functional firmware
- On-board voltage regulation
- Automatically retrieves data from modules on RTU bus
- Module is removable without disturbing field wiring
- Keyed to prevent damage
- Time-tagged messages
- Battery-backed clock/calendar synchronized by telemetry
- No on-board adjustments, switches or straps (selfconfiguring)
- Watchdog timer
- Gold edge connector fingers

LEDs

4 programmable LEDs and 8 hardware/firmware-controlled LEDs:

- Power (PWR)
- Module receive data (MRX)
- Module transmit data (MTX)
- Radio receive data (RRX)
- Radio transmit data (RTX)
- CPU failure (FLT)
- PLC033 status (STAT)
- Network status (LINK)

I/O

An I/O listing for the PLC001 is on page 76.

Wiring and Programming

Refer to the *PLC033 Installation and Operation Manual*, which is available for download from the DFS website (www.DataFlowSys.com)

Radio Interface Module (RIM006)

The Radio Interface Module (RIM) is a microprocessor-controlled module specifically designed for use with our TAC II Central Terminal Units (CTUs), Forwarding Terminal Units (FTUs) and 200 Series RTUs. The RIM, and its integrated radio, is inserted in the reserved “communication module” slot of a Modular Backplane (MBP). This module can interface with up to 15 I/O modules of any combination. The utility’s frequency and power requirements determine the RIM model used.

The RIM is able to support four levels of digipeating. This means the radio signal from a distant RTU can be routed to the central site by passing its message through three other RTUs. This is a powerful option for RTU locations that require short antenna heights or those with distance or terrain challenges.

The RIM includes a service port to provide communications link monitoring as well as the ability to directly monitor and/or control each module in the remote terminal unit using DFS provided WinRTU Test software.

LEDs

The RIM has status LEDs for:

- Power
- Rx (data received)
- Tx (data transmitted)
- Onboard hardware fault
- Test mode

I/O

An I/O listing for the RIM is on page 78.



Figure 16: Radio Interface Module (View 1)

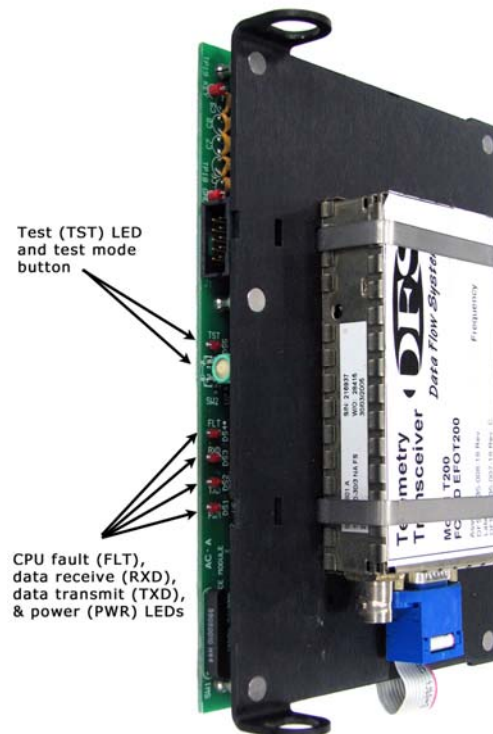

Figure 17: Radio Interface Module (View 2)

RDP180-C (Cellular RTU)

For cellular operation, an RDP180-C is equipped with a Verizon cell modem for communication. Each RDP180-C is given a unique mobile telephone number that requires its own data plan.

The Cellular SCADA System uses a pop-up scheme where the HSS operates as a “listener” via a special driver (Net DFP). Instead of polling the remotes, the HSS waits for messages from them. Each remote (Cellular RTU) stores status changes locally in an event table until one of four configured events occur. When an event occurs, the remote transmits information from the event table to the HSS, empties the event table, and begins accumulating event data again.

The Cellular RTUs send status updates to the Hyper SCADA Server over the Internet / Cell Phone network. The status update messages are sent to a static IP address assigned to the HSS by your Internet service provider.

The RDP180-C provides 9 discrete inputs, 2 discrete outputs, and one analog input as local I/O (I/O expansion is possible with the installation of additional equipment). Each Cellular RTU provides time stamped status of selected data point that is accurate to the second. This I/O as well as built-in Special Function Registers, which include such things as cell signal strength and power supply voltage, can be configured to report changes in status to the HSS.

System Requirements

- Good cellular coverage at RTU site
- Verizon data plan
- Hyper SCADA Server with HT3 3.1.1 or newer installed
- Computer or laptop with Process Management Toolkit (PMT) version 2.1.1 or newer installed
- Static IP address for HSS
- HSS that is accessible via the Internet

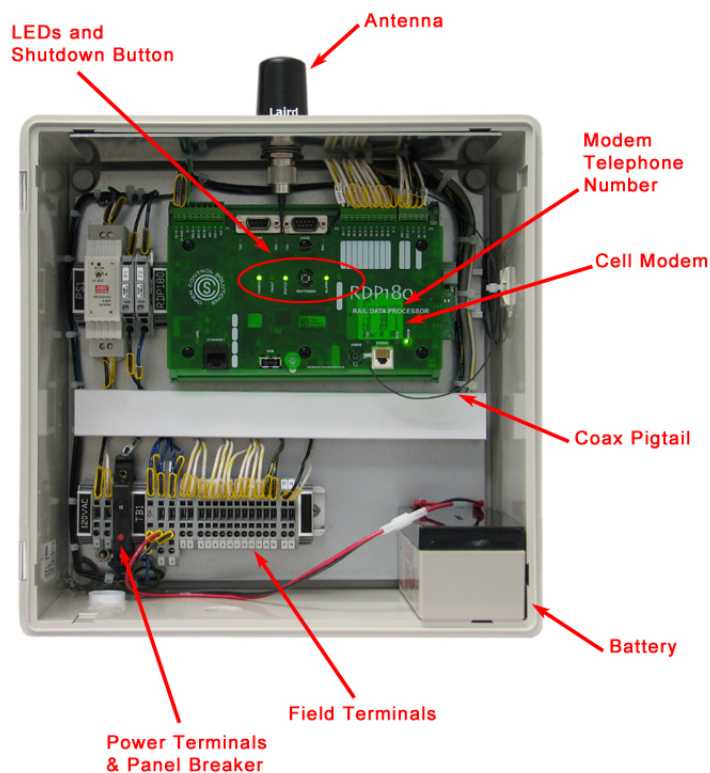

Figure 18: RDP180-C (Cellular RTU)

Solar Power Module (SPM002)

The Solar Power Module (SPM) is designed for RTU applications that require solar power. The SPM requires photovoltaic solar panel technology to capture energy from the sun. The nominal design requires a 40-watt solar panel and an 18 amp-hour sealed lead acid (SLA) battery; and provides power to an RTU202 for up to 3 days without sunlight. The SPM simultaneously powers the RTU and charges the SLA battery.

A solar-powered RTU202 is ideal for water-level monitoring, and when commercial power is not available or practical. Applications that require additional monitoring points or extended days without sunlight can be easily accommodated with a larger solar panel and battery.

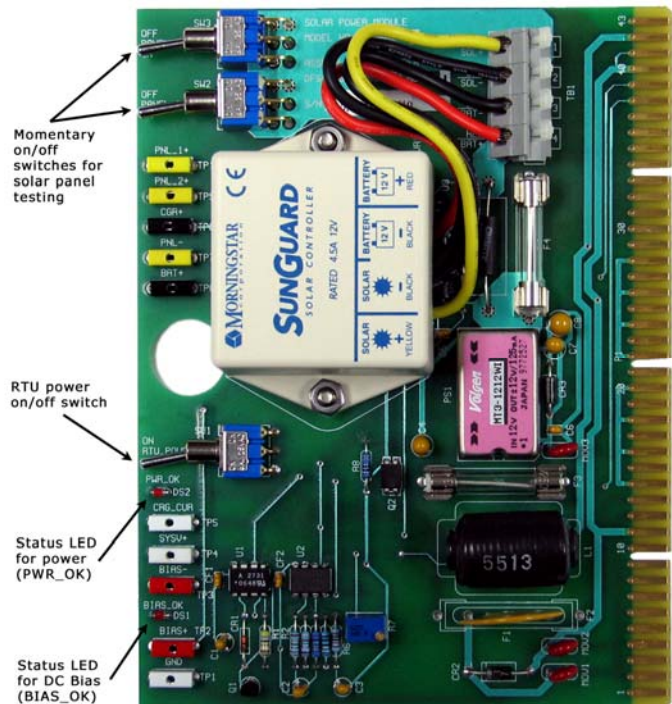

Figure 19: Solar Power Module

LEDs

The SPM has status LEDs for:

- Power (PWR_OK)
- DC bias (BIAS_OK)

I/O

An I/O listing for the SPM is on page 79.

Wiring

“Wiring a Solar Power Module (SPM),” page 57.

Telemetry Control Unit (TCU001)

DFS is an industry leader in providing pump controllers for thousands of pumping stations installed and operating nationwide. The Telemetry Control Unit (TCU), a SCADA ready pump controller, is designed specifically for level management applications such as Sewer Pump Stations, Lift Stations, and Water Storage Tanks.

Preconfigured to operate up to three fixed speed pumps, and incorporating most of the required control components, the TCU is easily installed and placed into operation without the need for PLC programming knowledge. The TCU is also customizable for advanced VFD control.

The Telemetry Control Unit (TCU) pump controller is a fully programmable, dual-function device. The TCU can be factory-programmed to control up to three fixed speed pumps; or it can be custom programmed for a specialized control application.

As a pump control device, the TCU contains all the hardware and software needed to control up to three motor starters based on level input. Float ball switches, pressure transducers, or other types of analog level sensors are supported.

When used as a custom-programmed device, the TCU can control up to six discrete devices, monitor up to 12 discrete inputs and monitor up to two analog devices.

The TCU features dual double-speed microcontrollers. One handles the control functions while the other manages the unit's communications. The TCU is available with an optional factory-integrated synthesized radio, network interface adapter, or a standard telephone line compatible autodialer.

An integrated AC phase monitor uses True RMS to produce accurate and exact 3-phase voltage readings. The analog inputs are 12-bit for superior accuracy and resolution. An auxiliary input function as a standard discrete input or pulse counter for a tipping bucket rain gauge. An RS-485 serial interface enables communication with industry-standard devices and VFD controllers. In addition, the unit features an RS-232 Serial Radio interface that supports both Modbus ASCII and Modbus RTU.

For ease of operator interface, the TCU incorporates a large 4x20-character LCD display and 12-button keypad. Eight LEDs surrounding the display are programmable for at-a-glance status indication.

For more information on the TCU, refer to the “TAC Pack TCU Installation & Operation Manual.”

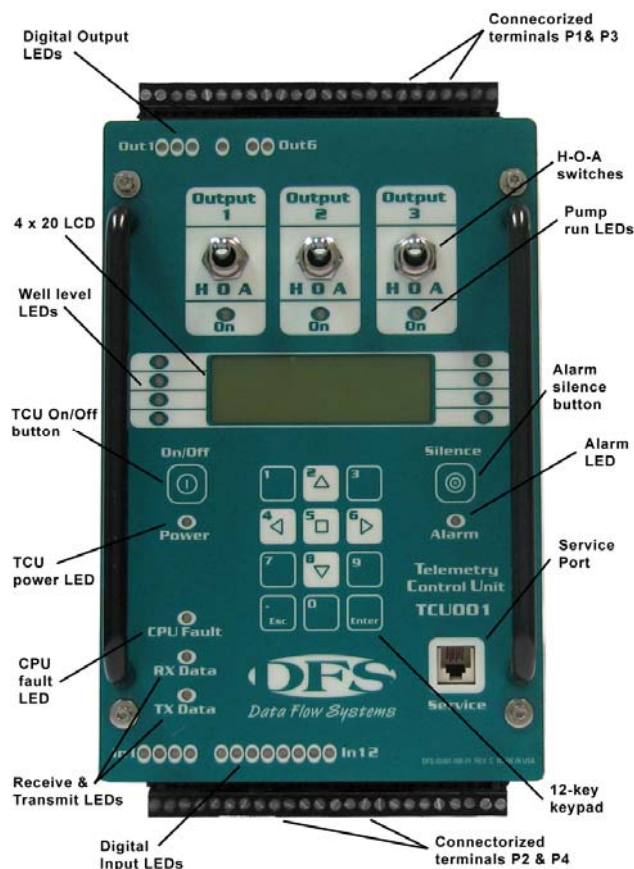

Figure 20: Telemetry Control Unit (TCU)

Telemetry Interface Module (TIM007)

The Telemetry Interface Module (TIM) is a microprocessor-controlled module with an integrated serial digital radio. The TIM is programmed to a customer-specific FCC licensed frequency and can interface with up to 15 I/O modules of any combination. The DFS TAC II SCADA System as a whole can accommodate up to (505) TIMs per communications link.

A data buffer on the TIM enables it to query its modules for status between radio polling loops and store that information until it is requested from the central site – a particularly useful feature for sites with long radio polling loops.

The TIM also features a wake up / report / sleep mode that aids in battery conservation in solar-powered applications.

The TIM supports four levels of digipeating (store and forward). Digipeating enables the radio signal from a distant RTU to be routed to the central site by passing its message through up to three RTUs. This is a powerful option for RTU locations that require short antenna heights or those with distance or terrain challenges.

The TIM is fully downward-compatible with the RIM006 and legacy T series radios.

LEDs

The TIM007 has status LEDs for:

- Power (PWR)
- Transmit data (TX)
- Receive data (RX)
- CPU fault (FLT)

I/O

An I/O listing for the TIM007 is on page 80.

Wiring

Refer to the *TIM007 Installation and Operation Manual*, which is available for download from the DFS website (www.DataFlowSys.com)

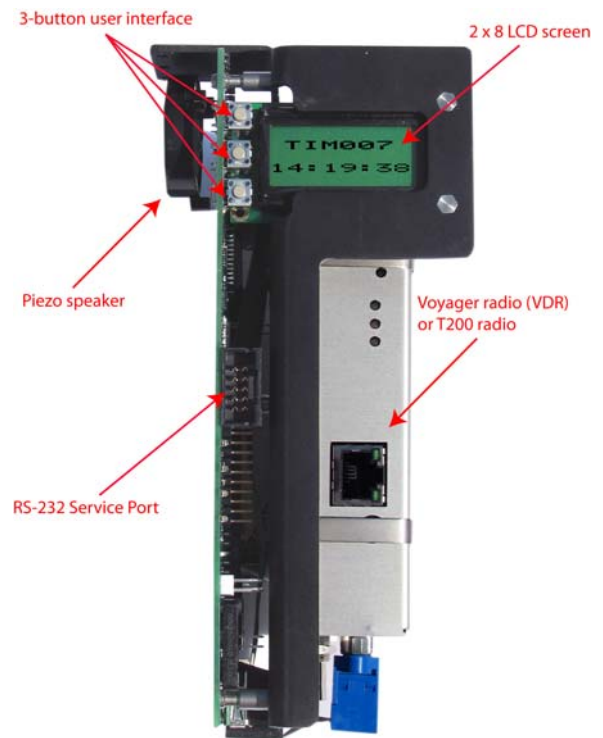

Figure 21: Telemetry Interface Module

Notes

Chapter 3: Pre-Installation Planning

Introduction

Ideally, a utility or their consultant has the experience to specify the functions required for their project, including the quantity and type of I/O needed at each site. However, we strongly recommend that a utility get DFS involved in the design and review process.

The following are specific events, and phases of work, to accomplish during installation:

- Radio Frequencies and Licensing
- Pre-construction planning and on-site surveys
- Ethernet Connectivity (if used as a mode of communication and/or Operator Workstations)
- Communication tower erection and SCADA Server installation
- Mounting panels, conduit runs, pulling wire, and connecting I/O points
- Testing and configuring remote sites into the Central Site
- Operator Training and Instruction

We separate installation into the listed events in order to allow employee and contractor specialization and for ease in scheduling and coordination. A separate individual, work crew, or contractor can accomplish each activity depending on their training, skill, and work schedule. The actual sequence and criticality of each event will depend on the size and complexity of each project.

Some immediate planning questions are:

- Is this project a new system requiring a central site and operator training; or is the project an add-on RTU site for an existing system?
- Is this a retrofit of an existing remote site? Is this job being done in conjunction with the construction of a new station?

Radio Frequencies and Licensing

Frequencies

When radio is utilized, the TAC II SCADA System will require the use of an FCC-licensed radio frequency. DFS will program the RIM (Radio Interface Module) or TAC Pack TCU for the proper frequency prior to installation or shipment. DFS radio products will comply with the specific operating parameters specified in the FCC license.

DFS exclusively uses FCC Licensed Frequencies in the VHF and UHF bands for their ideal performance characteristics and licensing protections. We do not recommend the use of licensed/unlicensed 900 MHz

frequencies or 2.4/5.8 GHz spread spectrum for SCADA communications due to their poor propagation characteristics and reliance on line-of-site path. Not to mention that VHF and UHF applications are significantly lower in cost compared to those in 900 MHz and spread spectrum. DFS can guarantee a VHF band anywhere in the USA. DFS will perform the radio link budgets and guarantee its performance when installed per our recommendations.

The purpose of any SCADA system is to provide monitoring, control and analytical data reporting. This helps to ensure the safe and reliable operation of the utility's wells, pump stations, plants, etc. To this end, it is imperative the utility has sole-owner control of its frequency and radio system. In our opinion, sharing frequencies and resources such as trunking systems do not provide reliable systems.

Every system requires a radio propagation study. Remote sites having long distances or interposing terrain features will require more extensive planning concerning the possible use of a Forwarding Terminal Unit or Digipeating. Factors including antenna heights, the gain of the various antenna styles available, and the attenuation of the coax cable are considered. All three have an impact on communication performance.

Licensing

DFS has the experience and resources to coordinate the frequency application in the name of the utility or municipality (owner).

Adding additional sites to an existing system is the easiest licensing situation, as the frequency is already known and operating. However, the FCC still requires that the utility process a complete application to add the new sites. Up to six sites may be included on each application form, and each application form will result in a different license number. Licenses must be posted at the master radio location.

Some of the information required on the license application are: latitude and longitude of each site; elevation of each site; height of each antenna to the tip; the gain of the antenna, the power of each radio; the effective radiated power from each site; and a physical address for each site location.

Site Surveys

Central Site

At the central site, determine the location of the CTU antenna tower, Hyper SCADA Server and the Primary Workstation Computer. The CTU enclosure is typically mounted on the antenna tower. How and where will you run the fiber-optic cable? Decide the routing, and designate where and how it should pass through walls. Where can you tap into the buildings electrical grounding grid? The Hyper SCADA Server and Workstation Computer(s) must be indoors and in a climate-controlled environment.

Other concerns at the Central Site include:

- Was special computer furniture ordered?
- Is there a remote workstation or some other off-site computer that you must connect to the Central Site? How is it connected, LAN, WAN, or modem?

- Are two separate phone lines available for the 411 dial-in and 911 alarm dial-out features?
- Who will monitor the system and respond to alarms? After normal work hours? Whom does it call? Will a cellular phone be required for on-call personnel?
- Operator training: Who, other than operators, should attend?

Remote Sites

At the spot the RTU tower will be installed, use a compass to analyze the antenna bearing as dictated by the radio study. Assure there are no immediate path obstructions such as a Ground Storage Tank, thick stand of pine trees, or power transformer. In this case, DFS will determine the required resolution.

Other items of concern include:

- Do you require special tools? For example, do you have to bore a 2 inch hole through the 12 inch concrete wall of a lift station in order to run control wires or float cables?
- Try not to place the antenna directly under a power line.
- The antenna should not face directly into high voltage power lines and transformers on utility poles.
- Property easements and right-of-ways may influence antenna placement.
- Underground locates must be done at all locations prior to installation.
- Do not let the tower block access to the generator receptacle on the control panel.
- Do not let the tower block access to the site for the local power company or the utility's maintenance crews.
- Is there a water supply on-site to mix concrete?
- Is there another contractor working on-site with whom you must coordinate?
- Are utility escorts required to gain access, or can crews have keys to the gates, buildings, and control panels?
- What are the working hours that you will permit?
- Coordination with the utility for special equipment (bucket-truck).

Considering the kinds of modules required, e.g., monitor only, monitor and control, PLC, etc., determine what components you must remove or relocate within the utility's control panel.

How should you wire the HOA switches? How much backup or redundancy does the utility want to keep within their control panel?

If you are not going to mount the RTU box directly to the antenna tower, determine an alternative location. While DFS does use a high quality, low-loss, antenna coax cable, remember that the radio signal strength is reduced with each foot of cable length. Try to locate the RTU as close to the antenna tower as possible to minimize the coaxial cable length between the antenna and the RTU.

OSHA/Safety Issues

Compliance with OSHA regulations and concern for employee safety must be paramount. Employees who are not trained and experienced with electrical and construction safety requirements must not work on your installation teams unattended.

Do not assume that all utilities are in compliance or fully concerned about the regulatory requirements. Supervisors of installation teams are directly responsible for safety and regulatory compliance of their team regardless of the actions taken by the utility or other on-site contractor.

OSHA regulation Title 29, Code of Federal Regulations, Section 1910 covers most of the safety requirements. 29 CFR 1910 Subpart S (1910.301 to 1910.399) specifically covers Electrical Safety Requirements.

Focus particularly on the following issues:

- 29 CFR 1910.146 Confined Space Operations
- 29 CFR 1910.333 Electrical Lockout/Tagout Requirements
- 29 CFR 1910.1030 Bloodborne Pathogens

Confined Space Operations

OSHA is very specific in its definitions. Wastewater lift stations and wet wells are classic examples of a “permit required confined space.” They have limited access, most have some level of Hydrogen Sulfide (H₂S) or other “sewer gases,” all are filled with waste water, and all are filled with human waste products.

Can-type lift stations qualify just as a “confined space.” However, can-type stations “have the potential to contain a hazardous atmosphere,” so must be treated as a permit space until testing and inspection determines their safety status.

DFS employees are not authorized to enter a confined space. DFS does not contract to work in permit spaces as a normal mode of operation. DFS employees are not trained in permit space operations, and are not equipped with the required PPE (personal protective equipment).

Lockout / Tagout Procedures

Lockout / Tagout is another area where OSHA closely focuses on compliance.

Many times the team installing the DFS equipment is just one of several contractors on the job site, and all are working toward the same job completion or startup date. We have experienced contractors and construction sites that are not familiar with DFS. They do not understand that the installation team is working on the station’s motor control circuits. The installation team must be very vigilant that the pump installer or some other instrumentation contractor does not energize a circuit.

Even if DFS is the only team at the remote site, they must guard against someone at the Central Site from energizing equipment by way of sending a control signal through the SCADA system.

Bloodborne Pathogens

The OSHA rules for Bloodborne Pathogens are primarily directed at employees working with human blood and medical products. However, the regulations do include employees that may be exposed to “other potentially infectious materials,” and that is defined as any kind of human body fluids.

Installation teams have the potential to be exposed to surfaces and equipment that have been exposed to human body fluids and wastes, e.g., pulling float balls out of wet wells to test trip alarms.

It is DFS’ recommendation that installation and service team members take the Hepatitis-B vaccination series.

Notes

Chapter 4: Central Site Installation

Introduction

The Central Site is composed of three parts:

1. The Hyper SCADA Server with Primary Operator Workstation, and its operating environment.
2. The central antenna, antenna tower, and CTU (Central Terminal Unit).
3. The data connection between the Hyper SCADA Server and CTU.

In a basic system, the Hyper SCADA Server with Primary Operator Workstation is not required for the utility's remote site equipment to operate properly. However, the smooth and continuous operation of the central site is becoming more critical to the utility's management team for the following reasons:

- The EPA is requiring more utilities to maintain accurate history records of pump run times and volumes in order to justify issuing new Certificates of Occupancy.
- More utilities are using their system to perform control functions at the remote sites, i.e. turn off pumps or open valves from the central plant.
- Routine incidents and “minor” spills are becoming major political and media events.
- Utility manpower to inspect remote sites physically is steadily shrinking.

The Central Site is normally the first site installed within the utility. The Hyper SCADA Server with Primary Operator Workstation are used to test and configure each remote site as it is brought on-line.

Hyper SCADA Server & Primary Operator Workstation

The Hyper SCADA Server is a self-contained data collection and information server housed in a lockable wall-mounted enclosure. Utilizing Client-Server Architecture, the Human Machine Interface (HMI) is a typical Client Desktop PC (Primary Operator Workstation) connected to the Hyper SCADA Server using any one of the multiple connectivity options available. As shown in the diagram below, the Hyper SCADA Server is the hub of the SCADA System. The Hyper SCADA Server couples the power of networking with the stability and versatility of the Linux Operating System and MySQL to offer a SCADA System Server that is secure, fast and reliable. Visit www.scadaserver.com for more detailed information about the Hyper SCADA Server and HT3 SCADA Software.

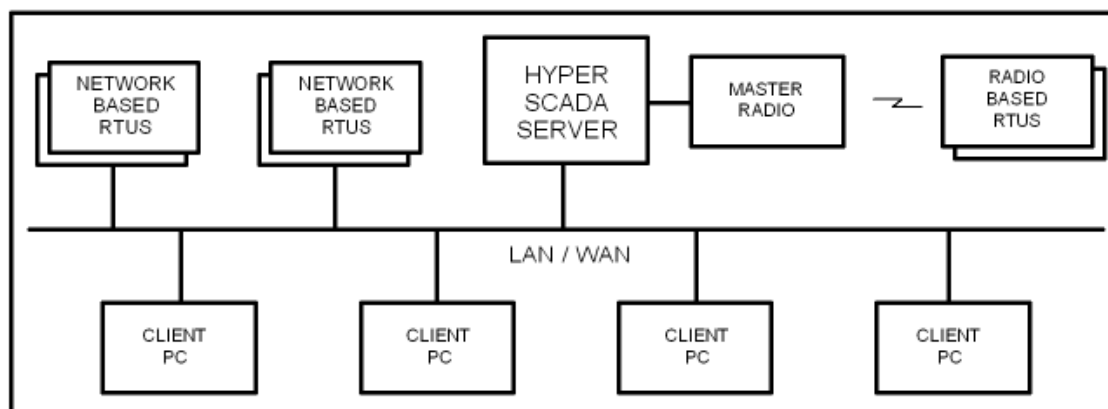

Figure 22: Typical Hyper SCADA Server System

The CTU and Central Antenna Tower

The central antenna is typically a high-gain, omni-directional antenna mounted as high as needed to communicate with all of the remote sites. If the central site is located at one end or one side of the utility's district, an offset antenna will provide better performance than an omni.

Remember, the radio signal requires a clear path going both ways. An obstruction that does not affect the signal going into a remote site may seriously affect communications coming out of that site.

If the central site antenna needs to be taller than 50 feet, you may want to subcontract the work to a tower erection company. Guy wires may be required for towers over 35 feet. Another option is mounting the antenna on a water tank, on top of a building, or adding a Forwarding Terminal Unit (FTU) to the system at another location.

Mount the CTU enclosure as close to the antenna as possible, but in a location where it will be easy to service. Keep the coax run as short as possible. The distance for the fiber optic cable run is not as critical.

Grounding the central site is important whether the CTU box is mounted directly to the antenna tower or not. Ensure a continuous ground wire is run from the tower to the CTU and then bonded to the building's ground.

The procedures for installing and wiring the functional modules into the CTU is the same as installing and wiring modules into the RTUs

Connecting the Hyper SCADA Server to the CTU

The data connection between the CTU and the Hyper SCADA Server is by fiber-optic cable. Twisted-pair wire is not an option and should not be used. Fiber-optic cable is the DFS standard because of its ability to isolate the server electrically from lightning strikes that may hit the central antenna.

The CTU enclosure houses a Modular Backplane, a PSM with backup battery, a RIM, and a FIM (Fiber Interface Module).

Electrical conduit to hold the FO cable should run between the CTU and the server location. 1" is the nominal size. Depending on the complexity of the conduit run, you may want to leave one end of the FO cable bare so it will pull easier. However, fabricating FO cable connectors in the field can be an exasperating task. DFS can fabricate and test the required cable lengths in its plant.

The preferred conduit for the central site is SCH 80, PVC because it eliminates a possible electrical path for transient voltage. The objective is to protect the server.

More information on this topic can be found in the *Hyper SCADA Server Installation and Operation Manual*, available for download from www.DataFlowSys.com.

Power Supply for the CTU

The PSM module in the CTU requires a 115 VAC commercial power source. There are two planning issues:

- Where can you tap into a reliable 115 VAC source to power the CTU?
- How will you know if the CTU loses commercial power?

Ideally, you will be able to wire the CTU and HSS into the same power feed used to operate the plant where emergency backup generator power is available. Then there is a high probability it will be in a circuit fed by utility emergency generator power if the plant loses outside, commercial power.

Both the CTU and HSS are designed with battery backup systems that will support the system for a limited period of time. Both the battery systems provide for a smooth and seamless transition from commercial power to emergency power and back again.

Notes

Chapter 5: Remote Site Installation

Introduction

There are several DFS approved antenna tower configurations available to accommodate location and wind load specifications. DFS has tower assemblies certified for up to 150 MPH wind loads.

The instructions below are not indented to be all inclusive; rather, they are intended to illustrate some of the planning and quality concerns that go into a DFS installation.

Phase I: Antenna Tower Erection & Preliminary Site Work

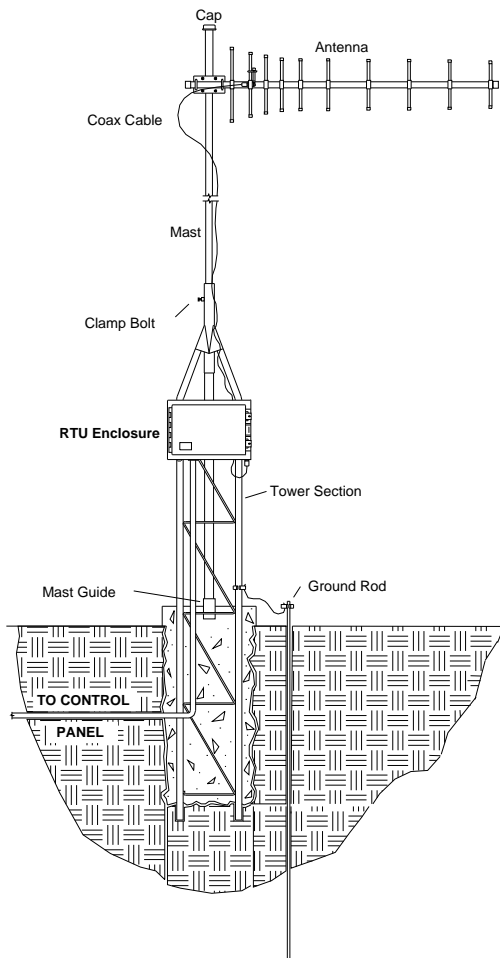

Figure 23: Typical Antenna Tower Installation

Only use antenna and tower parts supplied by, or specified by, DFS. In any case, only use stainless steel and hot-dipped galvanized components.

The following guide is for the basic DFS tower assembly.

Assemble Antenna and Tower

1. Remove the reducing sleeve in the top of the tower section by driving a short piece of 1¼” pipe up the mast guide.
2. Assemble the tower horizontally on the ground before erecting. Install the end cap onto the mast. Spray cap & threads with cold zinc.
3. Insert mast down into top of tower section and tighten clamp bolt such that mast end is 4 feet from the bottom of the tower section.
4. Attach the Yagi antenna 1 foot from the top of the mast using its enclosed mounting hardware.
5. Connect one end of the coax cable to the antenna and apply glue filled heat shrink over connection. Use vinyl coated, stainless steel, cable- ties to attach the coax to the mast to within 6” of tower section. Do not tie-wrap to the tower section yet.

Set Antenna Tower

1. Determine the location for the tower using the diagram from the site survey and paint markings on ground indicating location of tower, orientation of RTU enclosure and direction of antenna.
2. Dig the appropriate sized hole. Mix concrete using a good quality, “ready-mix” concrete.
3. Erect the tower into the hole and orientate so a flat side of the tower faces the direction you will mount the RTU box. Pour concrete around base, filling hole. Set 18” square cap form in place and fill with concrete. Level and plumb the tower.
4. Insert a 6” x 1” SCH 80 PVC pipe into the concrete cap--centered in the base of the tower section--and push down 3” into the concrete. This will act as a centering guide for the antenna mast.
5. Finish the concrete.

Mount Enclosure

1. Once the concrete has set up, mount the RTU box to the tower. The site survey diagram and paint markings will indicate on which side of the tower to mount the enclosure.
2. Connect the other end of the coax cable to the N-type connector on the bottom of the RTU enclosure. Ensure there is a smooth drip loop. Apply glue-filled heat shrink over coax connection. Finish tie-wrapping the coax to the tower.
3. Spray all exposed nut and bolt threads with cold zinc spray paint.

Ground Tower & Align Antenna

1. Remove the concrete form and install a copper ground clamp onto a tower leg. Drive in a 10' copper-clad ground rod for the tower. Bond the antenna tower, tower ground rod, RTU and Power Utilities ground. The grounds lugs and taps for all need to be bonded together using a continuous single 6 AWG solid bare copper wire
2. Loosen the mast clamp bolt at the top of the tower section, and lower mast over the PVC mast guide located in the center of the concrete base.
3. Turn the mast pole so the antenna points in the direction required. Use the direction indicated in the radio study. Lightly tighten clamp bolt. Final tightening will be after you run the radio test program that ensures the antenna is fine-tuned for best communications.

Phase II: Conduit & Panel Work

Determine the layout for the conduit runs required in each site. The simplest case is one run between a RTU box and a lift station control panel. Master lift stations and water plants can get quite extensive. Analog and Digital points must not occupy the same conduit.

You may install NEMA 4X enclosures in “damp and wet locations” as defined in the National Electrical Code. The white exterior is to help keep the interior cool when installed in outdoor locations. All fittings, mounts, brackets, nuts and bolts used in mounting the box should be of stainless steel. All other components should at least be hot-dipped galvanized or otherwise certified for outdoor and electrical use.

Running Conduit

The following are DFS standards for running conduit:

- SCH80 PVC. 1” is the nominal size.
- Buried conduit should conform to the NEC code.
- All entries into the RTU enclosure, and into the utility's control panel, should be through the bottom of the box.
- Flex-metal conduit should be vinyl coated and liquid tight.
- Analog signals and Digital points must be in separate conduit.

Phase III: Pulling Wire & Wiring I/O Points

DFS designed the TAC II RTU to make interfacing with the utility's control panel as easy as possible. **However, only qualified technicians should wire RTUs and Control Panels.**

The nominal wire size used in DFS installations is #16 AWG. Typical standards outlined by DFS are as follows:

- All digital inputs to the RTU will be of a dry contact type and terminal connections to be provided by the MCC manufacture/contractor.
- Mixing of multiple sources of power not permitted.
- All digital outputs from RTU will be dry contacts and provide for 120VAC at 10amp capacity.
- All analog inputs will be 4-20mA and at minimum to provide 500 ohm impedance drive
- All pulse input to be dry contact, and mechanically operated.

Wiring the Power Supply Module

The PSM is the only RTU module wired directly to a 115 VAC commercial power source. The standard 1000 watt, PSM003 draws 2 Amps of current. Most wiring schematics show #16 AWG wire being used throughout the RTU, which is more than adequate for the 2 A current draw. However, the point you tap for 115 VAC power will usually originate from a 20 Amp circuit breaker in the utility's control panel. You may have to use a heavier gauge wire or an interposing 10 A breaker in the utility's control panel, in order to comply with the local electrical code.

The PSM supplies 13.8 VDC operating power to the modules within the RTU. Additionally, it provides continuous charging to the backup battery. There is no wiring required for these functions as we have built all the connections into the RTU backplate.

Wiring a Digital Monitor Point

10-30 Volt Digital Monitor Point

Shown below is a wiring diagram for a 10-30 Volt Digital Monitor Point.

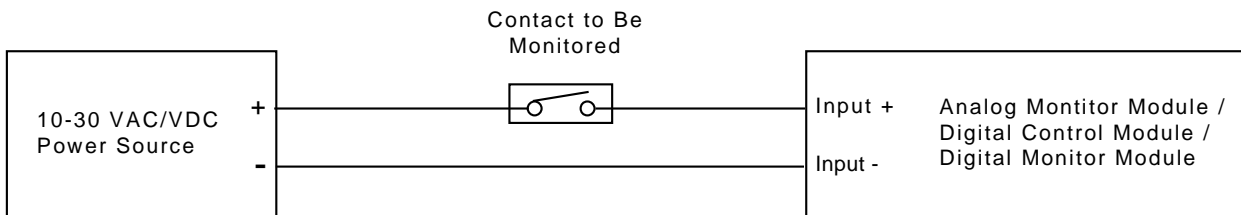

Figure 24: Digital Monitor Module Wiring for Low Voltage Monitoring

31-300 Volt Digital Monitor Point

Shown below is a wiring diagram for a 31-300 Volt Digital Monitor Point. Note that interposing relays are not required. The inputs to the module are optically isolated and protected from most transients. This can be valuable when monitoring AC power, or AC breaker & starter outputs.

Refer to “Table 2: Resistor Sizing” (below) when wiring for high voltage monitoring.

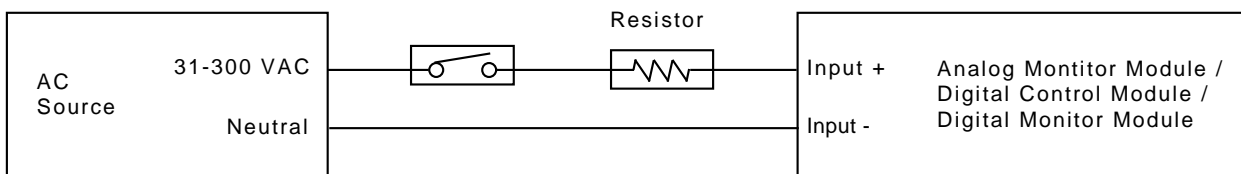

Figure 25: Digital Monitor Module Wiring for High Voltage Monitoring

Table 2: Resistor Sizing

Input Bias Voltage	Resistor Size
31-100 VAC	22K, ½ Watt
101-200 VAC	47K, ½ Watt
201-300 VAC	100K, 1 W

Wiring a Digital Control Point

Shown below is a wiring diagram for a Digital Control Point.

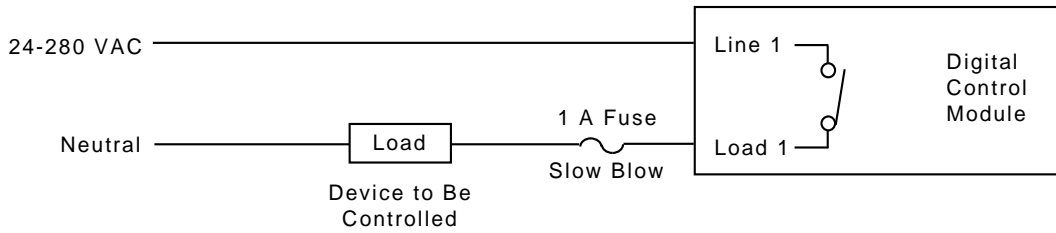

Figure 26: Digital Control Module Wiring

Wiring a Pulse Accumulator Point on a Digital Module (DCM/DMM)

Digital inputs on the Digital Monitor Module (DMM) and the Digital Control Module (DCM) can be used as pulse inputs. Shown below is a wiring diagram for a 10-30 Volt pulse accumulator point.

WARNING: Do not use AC power sources to monitor pulse accumulator points. This will result in erroneous pulse counts.

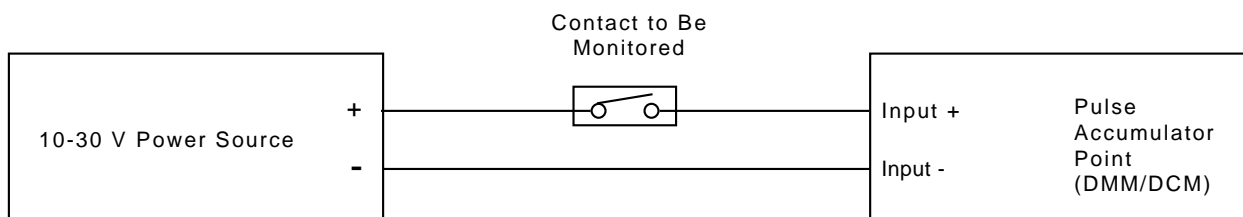

Figure 27: Digital Module Wiring (DCM/DMM) for 10-30V Pulse Accumulator Point

When configuring pulse inputs, be aware that HT3 expects a module's pulse inputs to be contiguous beginning with the last point on the module (point 12). For example, in order for HT3 to poll three (3) pulse inputs on a DMM002, you must configure points 12, 11, and 10 on the module as digital pulse (DP) points.

Wiring an Analog Monitor Point

The Analog Monitor Points are general purpose, optically isolated, analog inputs. In general, they can be wired as if they were a current or volt meter. Keep in mind that the inputs to the Analog Monitor Module (AMM) are protected from voltages higher than +35 VDC. This will not be a problem with 99.9% of the applications. However, there may be transducers that run off a very high voltage. In these instances, you should use a loop isolator to protect the AMM input. Also, make sure AC ground loops are minimized in the system. If an AC voltage greater than 28V is floating on the AMM input, it will be clamped by the protection circuit and cause erroneous readings.

Use shielded cabling when wiring analog signals. Connect cable shields to only one Earth Ground. Watch-out for inductive currents caused by running conductors for high voltage power or control circuits in the same area.

There are three basic ways to wire an Analog Monitor Point. They are:

1. 0-20 mA Current loop with transducer-supplied power (4- and 3-wire devices).
2. 0-20 mA Current loop with AMM-supplied power (2-wire devices).
3. 0-5 V Voltage source.

0-20mA Current Loop with Transducer-supplied Power

Shown below, you will see a current loop point with transducer-supplied power. Note that other loop monitoring devices (such as chart recorders, digital displays, etc.) can be placed in the loop. Be careful to get the positive and negative sides of each loop device in the proper direction. The AMM input derives no power from the loop. However, it does create a load across the 249-ohm “shunt” resistor for proper operation. This voltage will maximize at 5V for a full-scale input of 20 mA. If other devices are placed in the loop, be sure there is enough component drive supplied by the transducer to overcome the entire circuit’s burden.

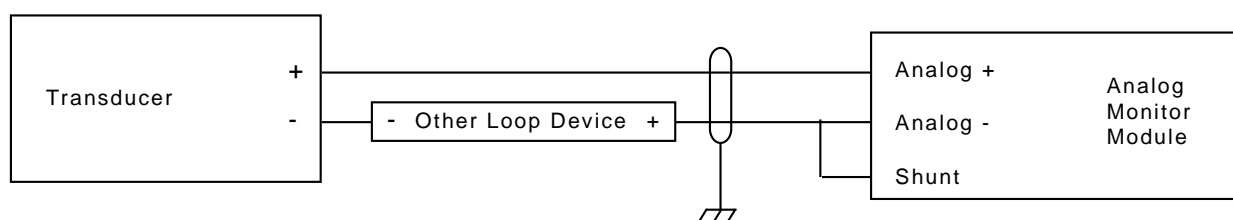

NOTE: Connect shield to ground in one place only

Figure 28: Analog Monitor Point Wiring (0-20 mA Current with Transducer Supplied Power)

0-20 mA Current loop with AMM-supplied power

Shown below is a current loop point with AMM-supplied power. Note that other loop monitoring devices (such as chart recorders, digital displays, etc.) can be placed in the loop. Be careful to get the positive and negative sides of each loop device in the proper direction. The AMM input derives no power from the loop. However, it does create a load across the internal shunt resistor of 250 ohm. This voltage will maximize at 5V for a full scale-input of 20 mA. If other devices are placed in the loop, be sure there is enough impedance drive supplied by the AMM to run all of them. By using the 24V bias to run the loop you will have 19 V left to power the transducer and other loop devices.

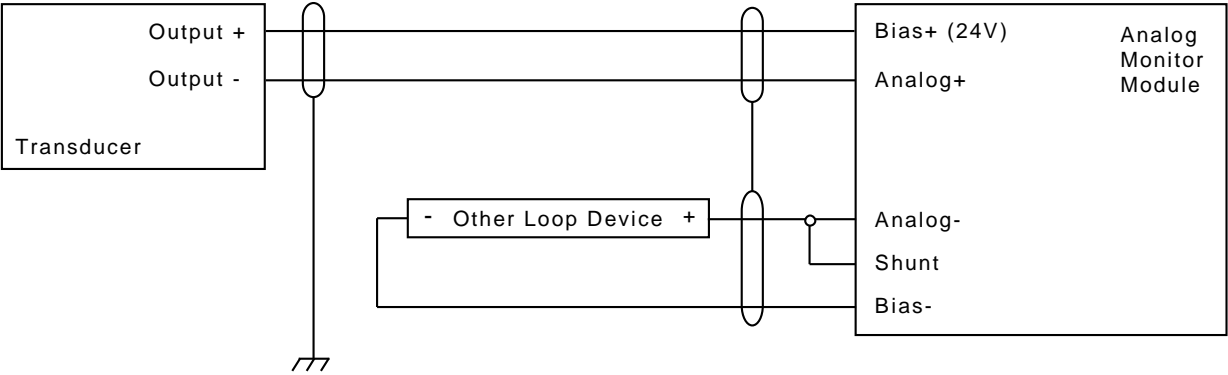

NOTE: Connect shield to ground in one place only

Figure 29: Analog Monitor Point Wiring (0-20 mA Current with AMM-supplied Power)

0-5 V Voltage source

Lastly, here is the wiring for a 0-5 V input signal. This mode of wiring is very susceptible to noise from other system components such as starters, motors and pumps. Be sure to use shielded cabling, and that it is grounded as shown.

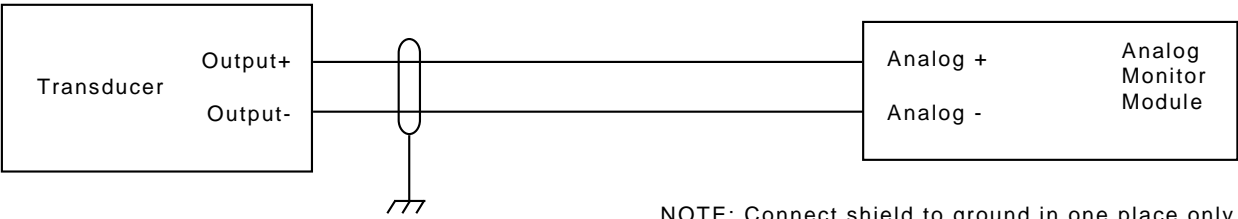

NOTE: Connect shield to ground in one place only

Figure 30: Analog Monitor Point Wiring (0-5 Volt)

Wiring an Analog Control Point

Shown below is the wiring diagram for an Analog Control Point. Note that other 4-20 mA loop devices such as chart recorders or digital displays can be inserted in the loop. Ensure that these devices do not overburden the circuit.

WARNING: Do not use the ACM with any other loop device that provides a loop bias. This may result in damaging the ACM and the other device.

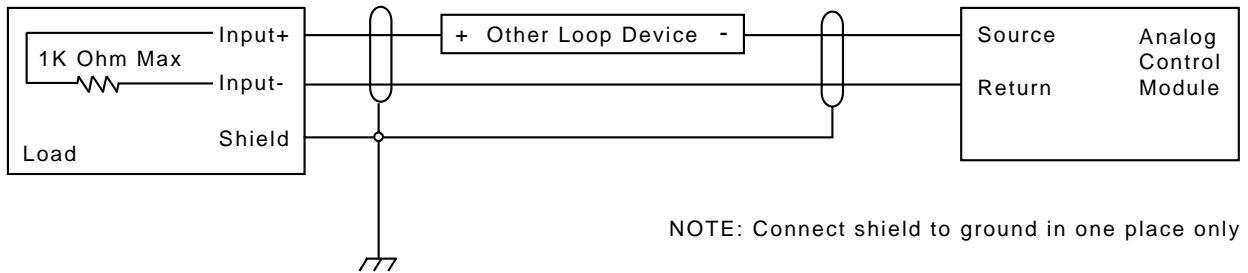

Figure 31: Analog Control Point Wiring

Wiring the RTU Side

Once you have determined which points need to be monitored, fill out an I/O Map for each of the modules in the RTU. Use wire IDs such as color codes or wire markers to identify each of the wires you will run between the RTU and the Control Panel.

RTU wiring does not terminate directly to the module cards. Rather, the wiring terminates on the Card Edge Connectors secured to the MBP. These connectors are specifically designed to function as wiring terminal blocks. Wires should be dressed throughout the RTU by tie-wrapping them to the tie down buttons on the plate.

Refer to Figure 33: Modular Backplane (MBP001) Used in RTU204 on page 54.

Addressing Modules

For a module to be properly recognized and polled by the HT3 server, it must be assigned an address, and the address must be configured in HT3 under the correct driver and station.

- For new model modular backplanes (MBP) equipped with jumper blocks (refer to Figure 33: Modular Backplane (MBP001) Used in RTU204 on page 54), the module address for each module slot is set at the factory. On these backplanes, pins on the module-address jumper block are punched out (removed) to set the module's address. (*Note:* A single jumper block is located between two slots and is used to address the slots on either side of it.) A replacement jumper block can be purchased from DFS to change the address. Alternatively, the jumper block can be removed and the module slot addressed as described below.
- For older model modular backplanes not equipped with jumper blocks, the module's address is set by placing jumpers on the appropriate pins (pins 35-43) on the module's spring-loaded terminal.

Each pin on the module address block and terminal has an assigned bit value. The station address is derived by totaling the values of the bits that are *not* grounded.

- On a module address block, the ungrounded bits are those where the pin has been punched out (removed). The module address is derived by totaling the bit values of the removed pins.
- On an older model RTU (one without address jumper blocks), a pin is grounded if it has been jumpered to pin 43 (ground). The module address is derived by totaling the bit values of the terminals that are *not* jumpered to Ground.

Module addresses are alphanumeric; ranging from A to O based on their bit value (i.e., A bit value of 1 is equivalent to the letter A; bit value of 2 is equivalent to the letter B, etc.).

The "Module address jumper block example," (next page) shows the pin settings for Modules A and B.

The "Terminal example" (next page) shows module address F.

Module addresses must be sequential (i.e., A, B, C).

Do not skip module addresses (e.g., addressing modules as A, D, F would be incorrect).

Module address jumper block example

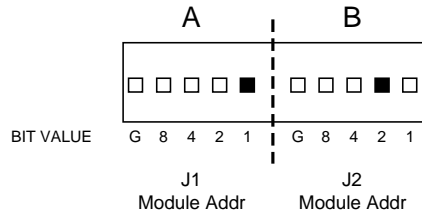

Terminal example

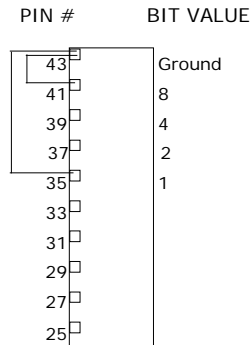

Figure 32: Addressing Modules

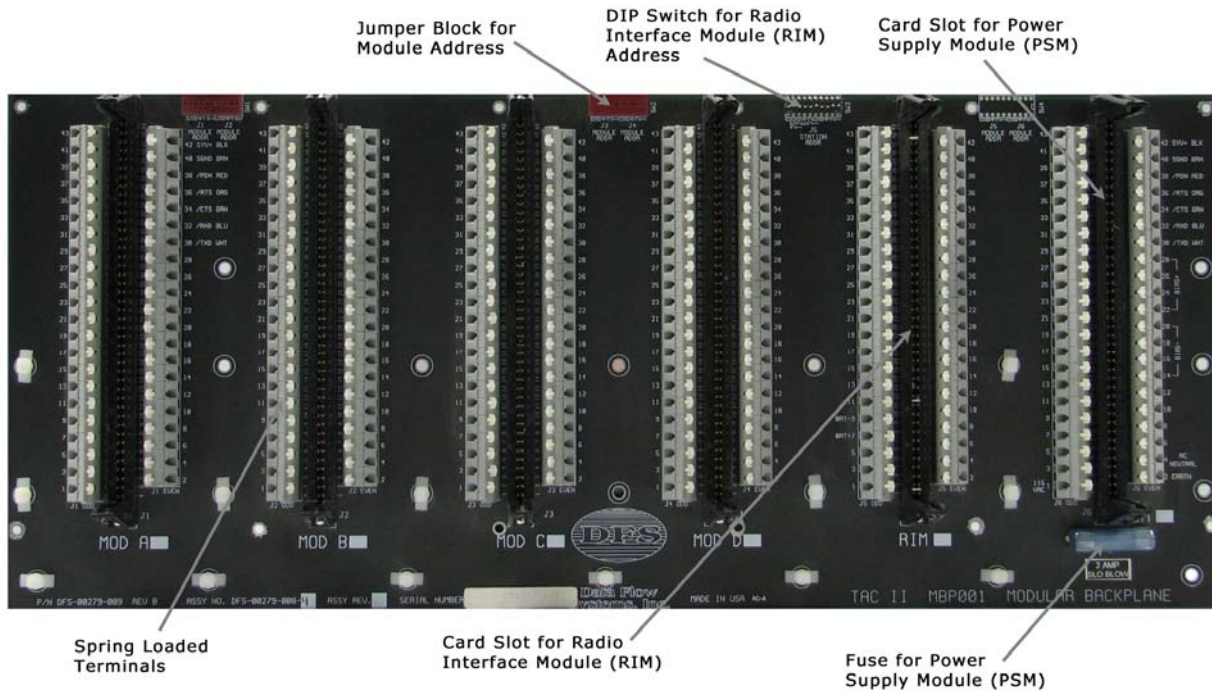

Figure 33: Modular Backplane (MBP001) Used in RTU204

Wiring a Bus Extender Module (BEM)

Typically, a BEM is used when the antenna at the site must be located some distance from the control panel being monitored. Additionally, a BEM can be used to incorporate a TAC Pack Telemetry Control Unit (TCU) into an RTU.

- In a standard installation, two BEMs and two enclosures are required: one enclosure with a RIM installed is mounted near the antenna (local RTU); another enclosure is installed next to the equipment being monitored (remote RTU).
- In a TCU installation – where the local BEM is connected to a TCU – only one BEM is required, because the TCU has a built-in BEM adapter.

Standard Installation (Local RTU to Remote RTU)

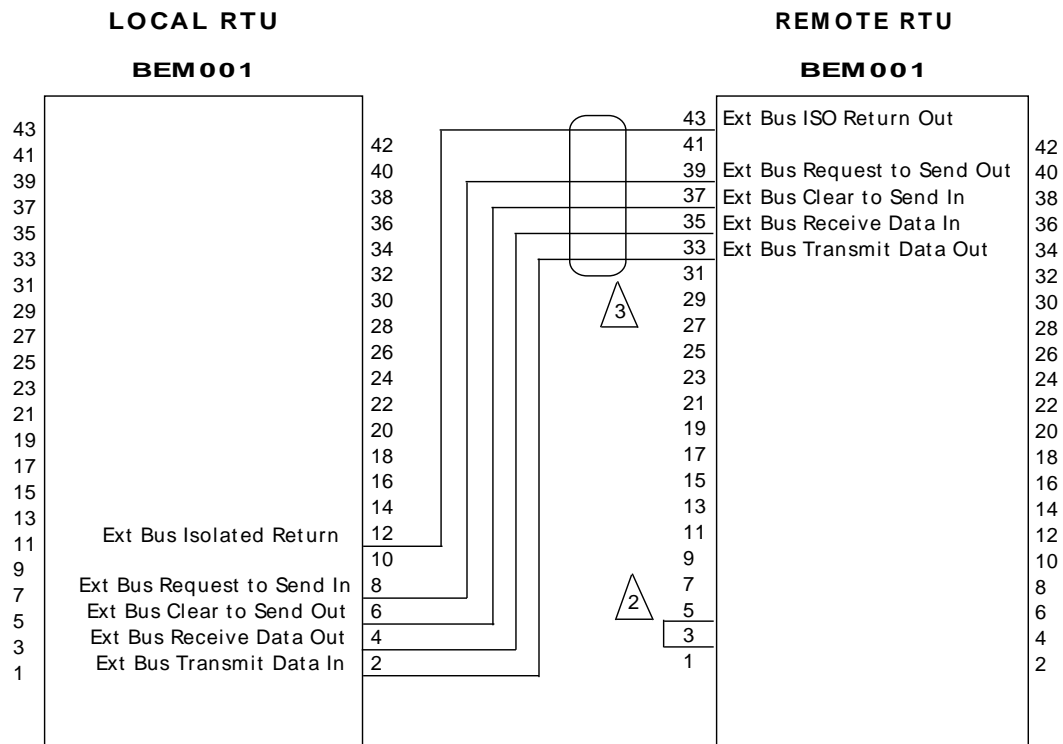

NOTES:

1. Do not install module or station address jumpers in BEM slot.
2. Jumper pins 3 and 5 on BEM in remote RTU (i.e., RTU with no RIM installed) ONLY when no start up plate is installed.
3. 6-conductor, 25-gauge shielded cable; maximum length 1000 feet.

Figure 34: BEM Wiring (Standard Installation)

TCU Installation (Local RTU to TCU)

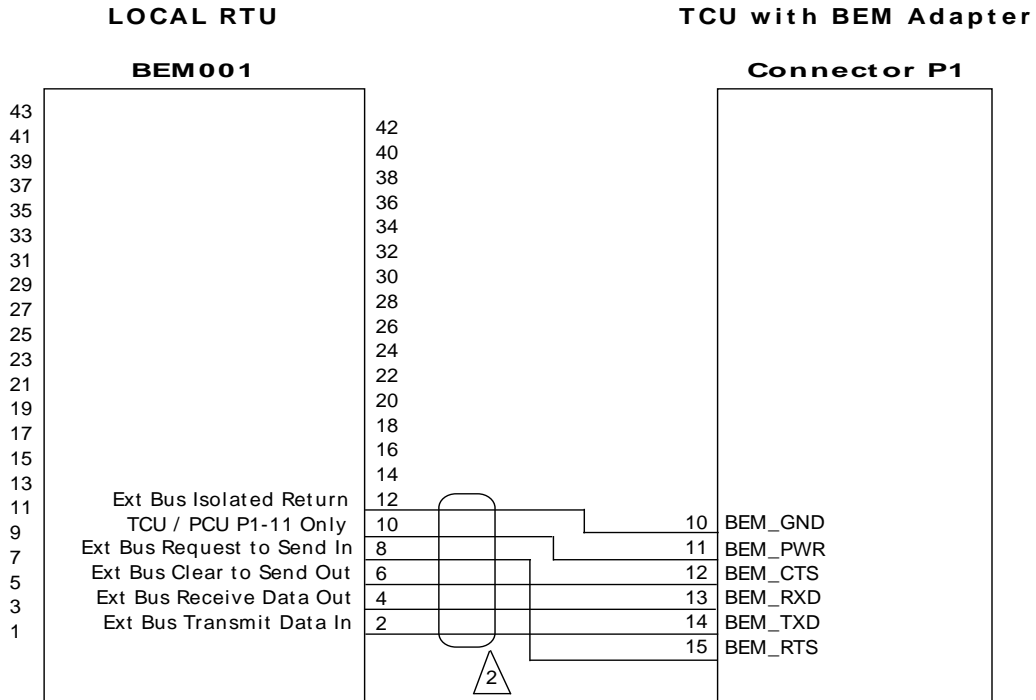

NOTES:

1. Do not install module or station address jumpers in BEM slot.
2. 6-conductor, 25-gauge shielded cable; maximum length 1000 feet.

Figure 35: BEM Wiring (TCU Installation)

Wiring a Solar Power Module (SPM)

The RTU202 (Rev. C1) is designed to accommodate solar power applications using the Solar Power Module (SPM002). The PSM slot is reconfigured by bringing the connections necessary for the SPM002 out to terminals. Nonessential components are removed from the board.

All solar installations should have an AMM installed in module slot A; and battery voltage should be wired to Analog Input 1. Optionally, the panel voltage can be wired to Analog Input 2.

Solar Panel 2 and Battery 2 are parallel to Panel 1 and Battery 1, respectively, on the SPM.

A typical solar power configuration is provided below.

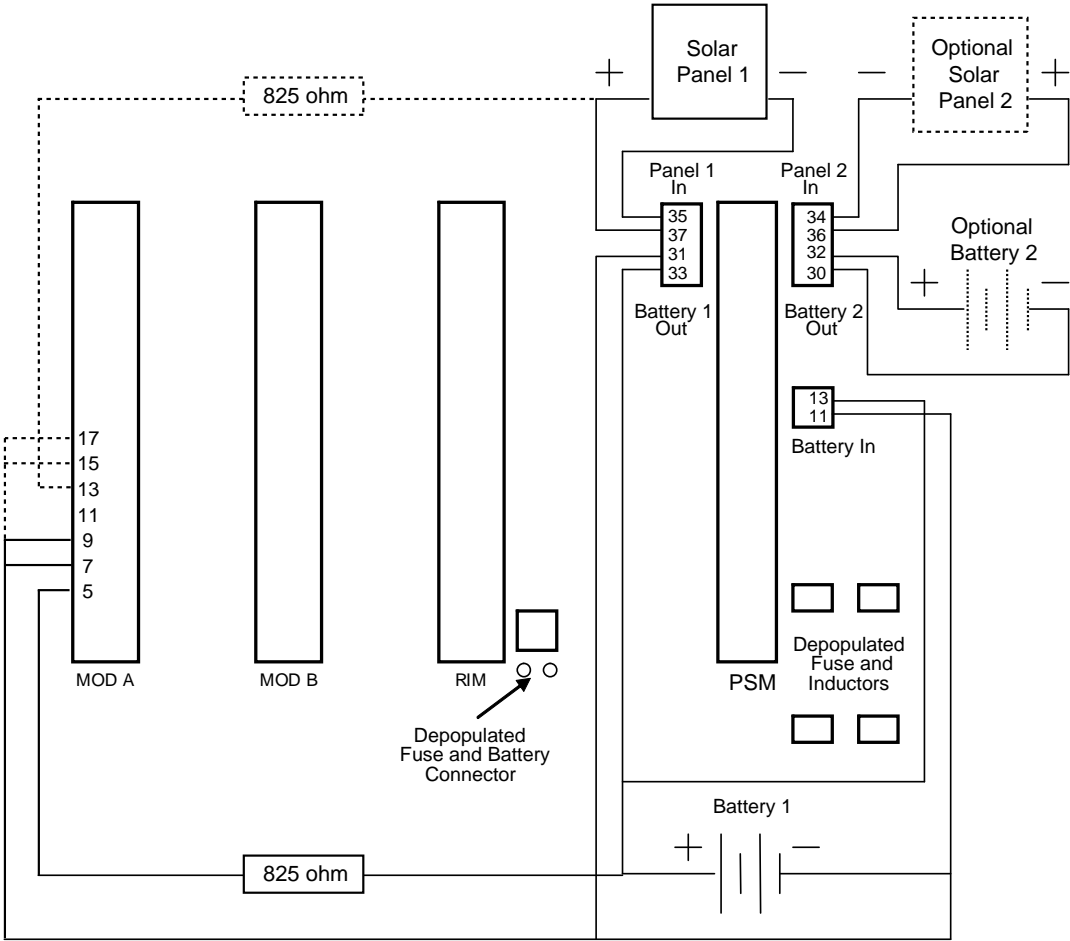

Figure 36: Solar Power Module Wiring

Wiring the Control Panel Side

Use I/O maps, and the utility's schematics, to make the wire connections in the control panel. Mount terminal strips to interpose between the control panel I/O points and the RTU wiring. DIN rail and WAGO® blocks are the DFS standard. Make sure voltage dropping resistors are not skipped on high voltage digital monitor points.

WARNING: Only qualified technicians should wire Control Panels.

Chapter 6: Module Testing, Alignment & RTU Configuration

Test Wiring

Verify that voltage-dropping resistors are installed on monitor points over 30 V. Before installing the actual function modules, use DFS test cards to test wiring of monitor and control points as described below. We designed these test cards to aid you in verifying proper wiring before installing, and possibly damaging, the more costly function modules.

Digital Monitor Test Card (DMTM001)

This test card provides 12 sets of test pins; two per monitor point. Install a volt meter between the “+” and “-” test pins for the point to be tested. Activate the utility’s device in the control panel connected to this monitor point, and verify that the meter reads as shown below. These are test readings, and may not be the actual voltages that appear on the inputs when a real card is installed.

Monitor	Low Voltage	120 VAC	240 VAC	480 VAC
Meter Reading	10-30 VAC or DC	55-65 VAC	70-90 VAC	80-100 VAC

In some applications, this card may be used to test Pulse Accumulator points. If the pulse transducer can be manually and continuously switched, instead of pulsed, you can use the above test for low voltage DC to verify the point wiring.

Digital Control Test Card

For each of the control points, toggle the test switch from off to on, and verify that it activates the corresponding control function in the control panel. Note that if the point is over current, the on-board circuit breaker will trip. If this should happen, correct the problem, reset the breaker, and re-test the point.

Install Modules

After you have tested the wiring, remove the test modules and install the actual modules. Install the card retainer plate.

Connect a laptop computer loaded with the WinRTU Test program. Use WinRTU Test to verify communications with the RIM, and to test the readouts of the monitor and control points to ensure they are accurate. Place the RIM in test mode to conduct these tests. Refer to the instructions included with WinRTU Test for information on these tests.

Test VSWR

Use a watt meter with the correct frequency “power slug” to ensure the radio has the specified output power, and less than 10:1 ratio in reflected power. You may continuously key the radio by depressing the test button while the RIM is in test mode.

Align Antenna

The objective is to fine-tune the alignment of the remote site antenna to ensure an optimal communications path. Make your initial alignment with a hand compass. Use the radio study information for the proper bearing.

Once you complete the initial alignment:

1. Temporarily install additional attenuation, as needed, between the radio and the antenna to continue testing.
2. Plug the testing laptop computer into the RIM service port.
3. Run the ANTENNA routine in WinRTU Test to verify the RTU is communicating on both RX and TX. Refer to the instructions included with WinRTU Test for information on performing this routine.
4. Turn the antenna for optimal alignment. Swing the antenna one direction until communications degrade. Then swing it the other direction until communications equally degrade. Position the antenna half way between these points.

Be sure to remove the attenuation and take the RIM out of test mode when done.

Final Checkout of the RTU Site

Verify that all circuit breakers and HOA switches are in the proper position, that the battery cable and radio pigtail are connected, and that the RTU circuit breaker is on. Remove card tags and fill out warranty form.

Before leaving any site, verify that the control panel is still functioning properly by activating floats or another input to cause the system to operate.

Configuring the RTU into the Central Site

The correct configuration of each RTU site into the Central Site is critical to ensure smooth operation of the total system. The following procedures emphasize the importance for the installation team to define and function-test station configurations, graphical screens, and alarm points properly when they bring new remote sites on-line.

We highly encourage utility personnel to be involved in the configuration, setup, and start-up process at the computer. However, unless specifically released by the customer, the installation team should assume responsibility to ensure that new RTUs are on-line and functioning properly both at the remote location *and* within the Hyper SCADA Server.

Phase III start-up procedures for the Central Site include the following:

- Properly address and configure the RTU site into the central.
- Configure alarms for critical points if required (normally done remotely by DFS Service Personnel).
- Test and confirm that the above actions are complete and functioning properly.
- Perform a joint review and hand-off, between the installation team and the customer, to confirm that both the remote site and the central site are functioning properly.

Whenever possible, perform joint sign-on and testing of new remote site configurations with utility personnel.

Detailed procedures for configuring remote sites into the central can be found in the Hyper SCADA Server Operation & Installation Manuals, or by using the system's "help" screens.

Notes

Chapter 7: RTU Input / Output (I/O) Sheets

Analog Control Module (ACM002)

Notes				Notes
	43	(Strap) Module Address Ground		
		System DC Voltage+ (Bus)	42	
	41	(Strap) Module Address Bit 3		
		System Ground (Bus)	40	
	39	(Strap) Module Address Bit 2		
		Power Down (Bus)	38	
	37	(Strap) Module Address Bit 1		
		Request To Send (Bus)	36	
	35	(Strap) Module Address Bit 0		
		Clear To Send (Bus)	34	
	33			
		Receive Data (Bus)	32	
	31			
		Transmit Data (Bus)	30	
	29			
			28	
	27			
			26	
	25			
			24	
	23			
		Transient Ground (Solid)	22	
	21			
			20	
	19			
			18	
	17			
			16	
	15	4-20 mA Return #4 (BK)		
4-AO*			14	
	13	4-20 mA Source Out #4 (WT)		
			12	
	11	4-20 mA Return #3 (BK)		
3-AO*			10	
	9	4-20 mA Source Out #3 (WT)		
			8	
	7	4-20 mA Return #2 (BK)		
2-AO*			6	
	5	4-20 mA Source Out #2 (WT)		
			4	
	3	4-20 mA Return #1 (BK)		
1-AO*			2	
	1	4-20 mA Source Out #1 (WT)		

* Corresponding configuration point in HT3.

** The ACM002 module has status LEDs for power (PWR, DS1), transmit data (TXD, DS2), receive data (RXD, DS3), and CPU failure (FLT, DS4). Refer to the ACM002 section of this manual beginning on page 15.

Analog Monitor Module (AMM002)

Notes				Notes
	43	(Strap) Module Address Ground		
		System DC Voltage+ (Bus)	42	
	41	(Strap) Module Address Bit 3		
		System Ground (Bus)	40	
	39	(Strap) Module Address Bit 2		
		Power Down (Bus)	38	
	37	(Strap) Module Address Bit 1		
		Request To Send (Bus)	36	
	35	(Strap) Module Address Bit 0		
		Clear To Send (Bus)	34	
If 4-20 mA, strap to pin 31	33	(BK) Shunt #4		
		Receive Data (Bus)	32	
	31	(BK) Analog #4-		
4-AI*		Transmit Data (Bus)	30	
	29	(WT/RD) Analog #4+		
			28	
	27	(WT/RD) 24 VDC+ Bias		
		System Ground	26	
If 4-20 mA, strap to pin 23	25	(BK) Shunt #3		
			24	
	23	(BK) Analog #3-		
3-AI*		Transient Ground (Solid)	22	
	21	(WT/RD) Analog #3+		
		Qualifier #1- (BK)	20	
	19	(WT/RD) 24 VDC+ Bias		5-DI* / QLF1, DS5**
		Qualifier #1+ (RD)	18	
If 4-20 mA, strap to pin 15	17	(BK) Shunt #2		
		Qualifier #2- (BK)	16	
	15	(BK) Analog #2-		6-DI* / QLF2, DS6**
2-AI*		Qualifier #2+ (RD)	14	
	13	(WT/RD) Analog #2+		
		Qualifier #3- (BK)	12	
	11	(WT/RD) 24 VDC+ Bias		7-DI* / QLF3, DS7**
		Qualifier #3+ (RD)	10	
If 4-20 mA, strap to pin 7	9	(BK) Shunt #1		
		Qualifier #4- (BK)	8	
	7	(BK) Analog #1-		8-DI* / QLF4, DS8**
1-AI*		Qualifier #4+ (RD)	6	
	5	(WT/RD) Analog #1+		
			4	
	3	(WT/RD) 24 VDC+ Bias		
			2	
	1	(BK) Bias Supply Return		

* Corresponding analog input (AI) or digital input (DI) point in HT3.

** Label of corresponding LED light on the module (each LED has two labels, e.g., QLF4, DS8). The module also has LEDs for power (PWR, DS1), transmit data (TXD, DS2), receive data (RXD, DS3), and CPU failure (FLT, DS4). Refer to the AMM002 section of this manual beginning on page 16.

Bus Extender Module (BEM)

Notes				Notes
(BU) BEM Pin #10	43	Ext Bus ISO Return Out		
		System DC Voltage+ (Bus)	42	
-- DO NOT CONNECT --	41			
		System Ground Bus	40	
(BN) BEM Pin #8	39	Ext Bus Request To Send Out		
		Power Down (Bus)	38	
(RD) BEM Pin #6	37	Ext Bus Clear To Send In		
		Request To Send (Bus)	36	
(WH) BEM Pin #4	35	Ext Bus Receive Data In		
		Clear To Send (Bus)	34	
(BK) BEM Pin #2	33	Ext Bus Transmit Data Out		
		Receive Data (Bus)	32	
	31			
		Transmit Data (Bus)	30	
	29			
		Power Supply Volts+ (Remote)	28	
	27			
		Power Supply Volts- (Remote)	26	
	25			
			24	
	23			
		Transient Ground (Solid)	22	
Ext Bus Shield	21			
			20	
	19			
			18	
	17			
			16	
	15			
		Ext Bus Shield	14	Ext Bus Shield
	13			
		Ext Bus Isolated Return	12	TCU / PCU P1-10 (BU)
	11			
		TCU / PCU P1-11 Only	10	TCU / PCU P1-11 (GN)
	9			
		Ext Bus Request To Send In	8	TCU / PCU P1-15 (BN)
	7			
		Ext Bus Clear To Send Out	6	TCU / PCU P1-12 (RD)
	5			
		Ext Bus Receive Data Out	4	TCU / PCU P1-13 (WT)
	3			
		Ext Bus Transmit Data In	2	TCU / PCU P1-14 (BK)
	1			

* The BEM module has status LEDs for power (PWR, DS1), transmit data (TXD, DS2), and receive data (RXD, DS3). Refer to the BEM section of this manual beginning on page 17.

Digital Control Module (DCM003-1)

Notes				Notes
	43	(Strap) Module Address Ground		
		System DC Voltage+ (Bus)	42	
	41	(Strap) Module Address Bit 3		
		System Ground (Bus)	40	
	39	(Strap) Module Address Bit 2		
		Power Down (Bus)	38	
	37	(Strap) Module Address Bit 1		
		Request To Send (Bus)	36	
	35	(Strap) Module Address Bit 0		
		Clear To Send (Bus)	34	
	33			
		Receive Data (Bus)	32	
	31	(GY/RD) AC Load Pt #8		
8-DO* / PT_8, DS20**		Transmit Data (Bus)	30	
	29	(RD) AC Line Pt #8		
			28	
	27	(GY/PK) AC Load Pt #7		
7-DO* / PT_7, DS19**			26	
	25	(PK) AC Line Pt #7		
			24	
	23	(GY/OR) AC Load Pt #6		
6-DO* / PT_6, DS18**		Transient Ground (Solid)	22	
	21	(OR) AC Line Pt #6		
		Input 4- (GY/YL)	20	
	19	(WT/YL) AC Load Pt #5		12-D1* / PT12, DS8**
5-DO* / PT_5, DS17**		Input 4+ (YL)	18	
	17	(BK/YL) AC Line Pt #5		
		Input 3- (GY/BN)	16	
	15	(WT/VL) AC Load Pt #4		11-D1* / PT11, DS7**
4-DO* / PT_4, DS16**		Input 3+ (BN)	14	
	13	(BK/VL) AC Line Pt #4		
		Input 2- (GY/VL)	12	
	11	(WT/RD) AC Load Pt #3		10-D1* / PT10, DS6**
3-DO* / PT_3, DS15**		Input 2+ (VL)	10	
	9	(BK/RD) AC Line Pt #3		
		Input 1- (GY/BU)	8	
	7	(WT/PK) AC Load Pt #2		9-D1* / PT_9, DS5**
2-DO* / PT_2, DS14**		Input 1+ (BU)	6	
	5	(BK/PK) AC Line Pt #2		
			4	
	3	(WT/OR) AC Load Pt #1		
1-DO* / PT_1, DS13**			2	
	1	(BK/OR) AC Line Pt #1		

* Corresponding configuration point in HT3.

** Label of corresponding LED light on the module (each LED has two labels, e.g., PT_1, DS13). The module also has LEDs for power (PWR, DS1), transmit data (TXD, DS2), receive data (RXD, DS3), and CPU failure (FLT, DS4). Refer to the DCM003 section of this manual beginning on page 18.

Digital Control Module (DCM003-2)

Notes				Notes
	43	(Strap) Module Address Ground		
		System DC Voltage+ Bus	42	
	41	(Strap) Module Address Bit 3		
		System Ground (Bus)	40	
	39	(Strap) Module Address Bit 2		
		Power Down (Bus)	38	
	37	(Strap) Module Address Bit 1		
		Request To Send (Bus)	36	
	35	(Strap) Module Address Bit 0		
		Clear To Send (Bus)	34	
	33			
		Receive Data (Bus)	32	
	31	(GY/RD) Input 8-		
8-D1* / PT_8, DS12**		Transmit Data (Bus)	30	
	29	(RD) Input 8+		
			28	
	27	(GY/PK) Input 7-		
7-D1* / PT_7, DS11**			26	
	25	(PK) Input 7+		
			24	
	23	(GY/OR) Input 6-		
6-D1* / PT_6, DS10**		Transient Ground (Solid)	22	
	21	(OR) Input 6+		
		Input 4- (GY/YL)	20	
	19	(WT/YL) Input 5-		12-D1* / PT12, DS8**
5-D1* / PT_5, DS9**		Input 4+ (YL)	18	
	17	(BK/YL) Input 5+		
		Input 3- (GY/BN)	16	
	15	(WT/VL) AC Load Pt #4		11-D1* / PT11, DS7**
4-DO* / PT_4, DS16**		Input 3+ (BN)	14	
	13	(BK/VL) AC Line Pt #4		
		Input 2- (GY/VL)	12	
	11	(WT/RD) AC Load Pt #3		10-D1* / PT10, DS6**
3-DO* / PT_3, DS15**		Input 2+ (VL)	10	
	9	(BK/RD) AC Line Pt #3		
		Input 1- (GY/BU)	8	
	7	(WT/PK) AC Load Pt #2		9-D1* / PT_9, DS5**
2-DO* / PT_2, DS14**		Input 1+ (BU)	6	
	5	(BK/PK) AC Line Pt #2		
			4	
	3	(WT/OR) AC Load Pt #1		
1-DO* / PT_1, DS13**			2	
	1	(BK/OR) AC Line Pt #1		

* Corresponding configuration point in HT3.

** Label of corresponding LED light on the module (each LED has two labels, e.g., PT_1, DS13). The module also has LEDs for power (PWR, DS1), transmit data (TXD, DS2), receive data (RXD, DS3), and CPU failure (FLT, DS4). Refer to the DCM003 section of this manual beginning on page 18.

Digital Control Module (DCM003-3)

Notes				Notes
	43	(Strap) Module Address Ground		
		System DC Voltage+ Bus	42	
	41	(Strap) Module Address Bit 3		
		System Ground (Bus)	40	
	39	(Strap) Module Address Bit 2		
		Power Down (Bus)	38	
	37	(Strap) Module Address Bit 1		
		Request To Send (Bus)	36	
	35	(Strap) Module Address Bit 0		
		Clear To Send (Bus)	34	
	33			
		Receive Data (Bus)	32	
	31	(GY/RD) AC/DC Load Pt #8		
8-DO* / PT_8, DS20**		Transmit Data (Bus)	30	
	29	(RD) AC/DC Line Pt #8		
			28	
	27	(GY/PK) AC/DC Load Pt #7		
7-DO* / PT_7, DS19**			26	
	25	(PK) AC/DC Line Pt #7		
			24	
	23	(GY/OR) AC/DC Load Pt #6		
6-DO* / PT_6, DS18**		Transient Ground (Solid)	22	
	21	(OR) AC/DC Line Pt #6		
		Input 4- (GY/YL)	20	
	19	(WT/YL) AC/DC Load Pt #5		12-D1* / PT12, DS8**
5-DO* / PT_5, DS17**		Input 4+ (YL)	18	
	17	(BK/YL) AC/DC Line Pt #5		
		Input 3- (GY/BN)	16	
	15	(WT/VL) AC/DC Load Pt #4		11-D1* / PT11, DS7**
4-DO* / PT_4, DS16**		Input 3+ (BN)	14	
	13	(BK/VL) AC/DC Line Pt #4		
		Input 2- (GY/VL)	12	
	11	(WT/RD) AC/DC Load Pt #3		10-D1* / PT10, DS6**
3-DO* / PT_3, DS15**		Input 2+ (VL)	10	
	9	(BK/RD) AC/DC Line Pt #3		
		Input 1- (GY/BU)	8	
	7	(WT/PK) AC/DC Load Pt #2		9-D1* / PT_9, DS5**
2-DO* / PT_2, DS14**		Input 1+ (BU)	6	
	5	(BK/PK) AC/DC Line Pt #2		
			4	
	3	(WT/OR) AC/DC Load Pt #1		
1-DO* / PT_1, DS13**			2	
	1	(BK/OR) AC/DC Line Pt #1		

* Corresponding configuration point in HT3.

** Label of corresponding LED light on the module (each LED has two labels, e.g., PT_1, DS13). The module also has LEDs for power (PWR, DS1), transmit data (TXD, DS2), receive data (RXD, DS3), and CPU failure (FLT, DS4). Refer to the DCM003 section of this manual beginning on page 18.

Digital Control Module (DCM003-4)

Notes				Notes
	43	(Strap) Module Address Ground		
		System DC Voltage+ (Bus)	42	
	41	(Strap) Module Address Bit 3		
		System Ground (Bus)	40	
	39	(Strap) Module Address Bit 2		
		Power Down (Bus)	38	
	37	(Strap) Module Address Bit 1		
		Request to Send (Bus)	36	
	35	(Strap) Module Address Bit 0		
		Clear to Send (Bus)	34	
	33			
		Receive Data (Bus)	32	
	31	(GY/RD) Input 8- Pt #8		
8-D1* / PT_8, DS12**		Transmit Data (Bus)	30	
	29	(RD) Input 8+ Pt #8		
			28	
	27	(GY/PK) Input 7- Pt #7		
7-D1* / PT_7, DS11**			26	
	25	(PK) Input 7+ Pt #7		
			24	
	23	(GY/OR) Input 6- Pt #6		
6-D1* / PT_6, DS10**		Transient Ground (Solid)	22	
	21	(OR) Input 6+ Pt #6		
		Input 4- Pt #12 (GY/YL)	20	
	19	(WT/YL) Input 5- Pt #5		12-D1* / PT12, DS8**
5-D1* / PT_5, DS9**		Input 4+ Pt #12 (YL)	18	
	17	(BK/YL) Input 5+ Pt #5		
		Input 3- Pt #11 (GY/BN)	16	
	15	(WT/VL) AC/DC Load Pt #4		11-D1* / PT11, DS7**
4-DO* / PT_4, DS16**		Input 3+ Pt #11 (BN)	14	
	13	(BK/VL) AC/DC Line Pt #4		
		Input 2- Pt #10 (GY/VL)	12	
	11	(WT/RD) AC/DC Load Pt #3		10-D1* / PT10, DS6**
3-DO* / PT_3, DS15**		Input 2+ Pt #10 (VL)	10	
	9	(BK/RD) AC/DC Line Pt #3		
		Input 1- Pt #9 (GY/BU)	8	
	7	(WT/PK) AC/DC Load Pt #2		9-D1* / PT_9, DS5**
2-DO* / PT_2, DS14**		Input 1+ Pt #9 (BU)	6	
	5	(BK/PK) AC/DC Line Pt #2		
			4	
	3	(WT/OR) AC/DC Load Pt #1		
1-DO* / PT_1, DS13**			2	
	1	(BK/OR) AC/DC Line Pt #1		

* Corresponding configuration point in HT3.

** Label of corresponding LED light on the module (each LED has two labels, e.g., PT_1, DS13). The module also has LEDs for power (PWR, DS1), transmit data (TXD, DS2), receive data (RXD, DS3), and CPU failure (FLT, DS4). Refer to the DCM003 section of this manual beginning on page 18.

Digital Control Module (DCM003-5)

Notes				Notes
	43	(Strap) Module Address Ground		
		System DC Voltage+ (Bus)	42	
	41	(Strap) Module Address Bit 3		
		System Ground (Bus)	40	
	39	(Strap) Module Address Bit 2		
		Power Down (Bus)	38	
	37	(Strap) Module Address Bit 1		
		Request to Send (Bus)	36	
	35	(Strap) Module Address Bit 0		
		Clear to Send (Bus)	34	
	33			
		Receive Data (Bus)	32	
	31	(GY/RD) DC Line Pt #8		
8-DO* / PT_8, DS20**		Transmit Data (Bus)	30	
	29	(RD) DC Load Pt #8		
			28	
	27	(GY/PK) DC Line Pt #7		
7-DO* / PT_7, DS19**			26	
	25	(PK) DC Load Pt #7		
			24	
	23	(GY/OR) DC Line Pt #6		
6-DO* / PT_6, DS18**		Transient Ground (Solid)	22	
	21	(OR) DC Load Pt #6		
		Input 4- (GY/YL)	20	
	19	(WT/YL) DC Line Pt #5		12-D1* / PT12, DS8**
5-DO* / PT_5, DS17**		Input 4+ (YL)	18	
	17	(BK/YL) DC Load Pt #5		
		Input 3- (GY/BN)	16	
	15	(WT/VL) DC Line Pt #4		11-D1* / PT11, DS7**
4-DO* / PT_4, DS16**		Input 3+ (BN)	14	
	13	(BK/VL) DC Load Pt #4		
		Input 2- (GY/VL)	12	
	11	(WT/RD) DC Line Pt #3		10-D1* / PT10, DS6**
3-DO* / PT_3, DS15**		Input 2+ (VL)	10	
	9	(BK/RD) DC Load Pt #3		
		Input 1- (GY/BU)	8	
	7	(WT/PK) DC Line Pt #2		9-D1* / PT_9, DS5**
2-DO* / PT_2, DS14**		Input 1+ (BU)	6	
	5	(BK/PK) DC Load Pt #2		
			4	
	3	(WT/OR) DC Line Pt #1		
1-DO* / PT_1, DS13**			2	
	1	(BK/OR) DC Load Pt #1		

* Corresponding configuration point in HT3.

** Label of corresponding LED light on the module (each LED has two labels, e.g., PT_1, DS13). The module also has LEDs for power (PWR, DS1), transmit data (TXD, DS2), receive data (RXD, DS3), and CPU failure (FLT, DS4). Refer to the DCM003 section of this manual beginning on page 18.

Digital Control Module (DCM003-6)

Notes				Notes
	43	(Strap) Module Address Ground		
		System DC Voltage+ (Bus)	42	
	41	(Strap) Module Address Bit 3		
		System Ground (Bus)	40	
	39	(Strap) Module Address Bit 2		
		Power Down (Bus)	38	
	37	(Strap) Module Address Bit 1		
		Request to Send (Bus)	36	
	35	(Strap) Module Address Bit 0		
		Clear to Send (Bus)	34	
	33			
		Receive Data (Bus)	32	
	31	(GY/RD) Input 8-		
8-D1* / PT_8, DS12**		Transmit Data (Bus)	30	
	29	(RD) Input 8+		
			28	
	27	(GY/PK) Input 7-		
7-D1* / PT_7, DS11**			26	
	25	(PK) Input 7+		
			24	
	23	(GY/OR) Input 6-		
6-D1* / PT_6, DS10**		Transient Ground (Solid)	22	
	21	(OR) Input 6+		
		Input 4- (GY/YL)	20	
	19	(WT/YL) Input 5-		12-D1* / PT12, DS8**
5-D1* / PT_5, DS9**		Input 4+ (YL)	18	
	17	(BK/YL) Input 5+		
		Input 3- (GY/BN)	16	
	15	(WT/VL) DC Line Pt #4		11-D1* / PT11, DS7**
4-DO* / PT_4, DS16**		Input 3+ (BN)	14	
	13	(BK/VL) DC Load Pt #4		
		Input 2- (GY/VL)	12	
	11	(WT/RD) DC Line Pt #3		10-D1* / PT10, DS6**
3-DO* / PT_3, DS15**		Input 2+ (VL)	10	
	9	(BK/RD) DC Load Pt #3		
		Input 1- (GY/BU)	8	
	7	(WT/PK) DC Line Pt #2		9-D1* / PT_9, DS5**
2-DO* / PT_2, DS14**		Input 1+ (BU)	6	
	5	(BK/PK) DC Load Pt #2		
			4	
	3	(WT/OR) DC Line Pt #1		
1-DO* / PT_1, DS13**			2	
	1	(BK/OR) DC Load Pt #1		

* Corresponding configuration point in HT3.

** Label of corresponding LED light on the module (each LED has two labels, e.g., PT_1, DS13). The module also has LEDs for power (PWR, DS1), transmit data (TXD, DS2), receive data (RXD, DS3), and CPU failure (FLT, DS4). Refer to the DCM003 section of this manual beginning on page 18.

Digital Monitor Module (DMM002)

Notes				Notes
	43	(Strap) Module Address Ground		
		System DC Voltage+ (Bus)	42	
	41	(Strap) Module Address Bit 3		
		System Ground (Bus)	40	
	39	(Strap) Module Address Bit 2		
		Power Down (Bus)	38	
	37	(Strap) Module Address Bit 1		
		Request to Send (Bus)	36	
	35	(Strap) Module Address Bit 0		
		Clear to Send (Bus)	34	
	33			
		Receive Data (Bus)	32	
	31			
		Transmit Data (Bus)	30	
	29			
			28	
	27	(GY/OR) Input 7-		
7-DI* / IN7, DS12**			26	
	25	(OR) Input 7+		
			24	
	23	(GY/PK) Input 6-		
6-DI* / IN6, DS11**		Transient Ground (Solid)	22	
	21	(PK) Input 6+		
		Input 12- (WT)	20	
	19	(GY/RD) Input 5-		12-DI* / IN12, DS17**
5-DI* / IN5, DS10**		Input 12+ (GY)	18	
	17	(RD) Input 5+		
		Input 11- (WT/PK)	16	
	15	(GY/BU) Input 4-		11-DI* / IN11, DS16**
4-DI* / IN4, DS9**		Input 11+ (BK/PK)	14	
	13	(BU) Input 4+		
		Input 10- (WT/RD)	12	
	11	(GY/VL) Input 3-		10-DI* / IN10, DS15**
3-DI* / IN3, DS8**		Input 10+ (BK/RD)	10	
	9	(VL) Input 3+		
		Input 9- (WT/VL)	8	
	7	(GY/BN) Input 2-		9-DI* / IN9, DS14**
2-DI* / IN2, DS7**		Input 9+ (BK/VL)	6	
	5	(BN) Input 2+		
		Input 8- (WT/YL)	4	
	3	(GY/YL) Input 1-		8-DI* / IN8, DS13**
1-DI* / IN1, DS6**		Input 8+ (BK/YL)	2	
	1	(YL) Input 1+		

* Corresponding configuration point in HT3; these points can also be configured as pulse input points. See "Adding and Configuring a Digital Pulse Point" in the *HT3 User Guide*.

** Label of corresponding LED light on the module (each LED has two labels, e.g., IN1, DS6); the module also has LEDs for power (PWR, DS1), transmit data (TXD, DS2), receive data (RXD, DS3), and CPU failure (FLT, DS4). Refer to the DMM002 section of this manual beginning on page 20.

Fiber Interface Module (FIM001)

Notes				Notes
	43	Station Address Ground		
		System V+	42	
		=KEY=		
	41	Station Address Bit 7		
		System Ground	40	
	39	Station Address Bit 6		
		Power Down	38	
	37	Station Address Bit 5		
		Request to Send	36	
	35	Station Address Bit 4		
		Clear to Send	34	
	33	Station Address Bit 3		
		Receive Data	32	
	31	Station Address Bit 2		
		Transmit Data	30	
	29	Station Address Bit 1		
		(PSM) Power Supply V+	28	
	27	Station Address Bit 0		
		(PSM) Power Supply Ground	26	
	25	Station Address Bit 8		
		(PSM) Power Supply Control	24	
	23	Program Strap 3		
			22	
	21	Program Strap 2		
		(PSM) / RTU Power OK	20	
	19	Program Strap 1		
		(PSM) / Bias OK	18	
	17	Program Strap 0		
		232 CTS 2	16	
	15	Program Strap Ground		
		232 RTS 2	14	
	13	232 CTS 1		
		232 GND 2	12	
		=KEY=		
	11	232 RTS 1		
		232 TXD 2	10	
	9	Battery Ground		
		232 RXD 2	8	
	7	Battery V+		
		232 GND 1	6	
	5	/Power Up		
		232 TXD 1	4	
	3	Redundant Power Supply Ground		
		=KEY=		
		232 RXD 1	2	
	1	Redundant Power Supply V+		

* Refer to the FIM001 section of this manual beginning on page 21 and to the *Network Interface & Distribution Modules Installation and Operation Manual* (available for download from www.DataFlowSys.com).

Power Supply Module (PSM003)

Notes					Notes
	43				
		System DC Voltage+ (Bus)		42	
	41				
		System Ground (Bus)		40	
	39				
				38	
	37				
				36	
	35				
				34	
	33				
				32	
	31				
				30	
	29	Power Supply+			
			VDC Bias+	28	Output Bias+
	27	Power Supply Ground			
			VDC Bias+	26	Output Bias+
	25	Power Supply Control			
			VDC Bias+	24	Output Bias+
	23				
			VDC Bias+	22	Output Bias+
	21	RTU Power OK			
			VDC Bias-	20	Return Bias-
	19	Bias OK			
			VDC Bias-	18	Return Bias-
	17				
			VDC Bias-	16	Return Bias-
	15				
			VDC Bias-	14	Return Bias-
	13				
		Transient Ground		12	
	11				
		AC Neutral Bus (WH)		10	
	9	(BK) AC Hot Bus			
		AC Neutral Bus (WH)		8	
	7	(BK) AC Hot Bus			
		AC Neutral Bus (WH)		6	
	5	(BK) AC Hot Bus			
		AC Neutral Bus (WH)		4	120 VAC Neutral input
	3	(BK) 230 VAC Hot Input			
		Ground Input (GR)		2	Safety Ground Input
120 VAC Line Input	1	(BK) 120 VAC Hot Input			

* The PSM003 module has status LEDs for bias, power, and shut down. Refer to the PSM003 section of this manual beginning on page 22.

Programmable Logical Control Module (PLC001)

Notes				Notes
	43	Local Modules System DC Voltage+		
		RIM System DC Voltage+	42	
	41	Local Modules System Ground		
		RIM System Ground	40	
	39	Local Modules / Power Down		
		RIM / Power Down	38	
	37	Local Modules / Request to Send		
		RIM / Request to Send	36	
	35	Local Modules / Clear to Send		
		RIM / Clear to Send	34	
	33	Local Modules / Receive Data		
		RIM / Receive Data	32	
	31	Local Modules / Transmit Data		
		=KEY=		
		RIM / Transmit Data	30	
	29	CFG Ground		
			28	
	27	CFG Run/Trap; 0FFFFH Config Bit 4 = (8)		
			26	
	25	0FFFFH Config Bit 3 = (4)		
			24	
	23	0FFFFH Config Bit 2 = (2)		
			22	
	21	0FFFFH Config Bit 1 = (1)		
			20	
	19			
			18	
	17			
			16	
	15			
			14	
	13			
		=KEY=		
			12	
	11			
			10	
	9			
			8	
	7			
			6	
	5	Host 232 GND		
			4	
	3	Host 232 TXD		
			2	
	1	Host 232 RXD		

* The PLC001 module has four (4) programmable LEDs (DS7, DS8, DS9, DS10) and six (6) hardware/firmware controlled LEDs: power (PWR, DS1), transmit data to local module (M_TXD, DS2), receive data from local module (M_RXD, DS3), CPU failure (FLT, DS4), transmit data to radio (R_TXD, DS5), receive data from radio (R_RXD, DS6). Refer to the PLC001 section of this manual beginning on page 23 and to the *PLC001/SCU001 Operations Guide and DFS BASIC-52 Reference* (available for download from www.DataFlowSys.com).

Programmable Logic Controller (PLC033)

Notes				Notes
	43	Local Modules System DC Voltage+		
		RIM System DC Voltage+	42	
	41	Local Modules System Ground		
		RIM System Ground	40	
	39	Local Modules/Power Down		
		RIM / Power Down	38	
	37	Local Modules / Request to Send		
		RIM / Request to Send	36	
	35	Local Modules / Clear to Send		
		RIM / Clear to Send	34	
	33	Local Modules / Receive Data		
		RIM / Receive Data	32	
	31	Local Modules / Transmit Data		
		=KEY=		
		RIM / Transmit Data	30	
Jump pin 27 to 29 for debug mode	29	CFG Ground		
			28	
	27	CFG Run/Trap; OFFFFH Config Bit 3 = (8)		
			26	
	25	Config Bit 2 = (4)		
			24	
	23	Config Bit 1 = (2)		
			22	
	21	Config Bit 0 = (1)		
			20	
	19	Config Bit 5 = (32)		
			18	
	17	Config Bit 4 = (16)		
			16	
	15	RS-485 B		
			14	
	13	RS-485 A		
		=KEY=		
			12	
	11	RS-485 Shield		
			10	
	9	Host 232 CTS		
			8	
	7	Host 232 RTS		
			6	
	5	Host 232 Ground		
			4	
	3	Host 232 TXD		
			2	
	1	Host 232 RXD		

* The PLC033 module has four (4) programmable LEDs (DS9, DS10, DS11, DS12) and eight (8) hardware/firmware controlled LEDs: power (PWR, DS2), module receive data (MRX, DS4), module transmit data (MTX, DS3), radio receive data (RRX, DS8), radio transmit data (RTX, DS7), CPU failure (FLT, DS5), PLC033 status (STAT, DS6), and network status (LINK, DS1). Refer to the PLC033 section of this manual beginning on page 25 and to the *PLC033 Installation and Operation Manual* (available for download from www.DataFlowSys.com).

Pump Control Module (PCM001)

Notes				Notes
	43	(Strap) Module Address Ground		
		System DC Voltage+ (Bus)	42	
	41	(Strap) Module Address Bit 3		
		System Ground (Bus)	40	
	39	(Strap) Module Address Bit 2		
		Power Down (Bus)	38	
	37	(Strap) Module Address Bit 1		
		Request to Send (Bus)	36	
	35	(Strap) Module Address Bit 0		
		Clear to Send (Bus)	34	
	33	(Strap) Module Config Bit 3		
	Receive Data (Bus)	32		
	31	(Strap) Module Config Bit 2		
	Transmit Data (Bus)	30		
	29	(Strap) Module Config Bit 1		
		(BK/YL)	28	Alarm Bell Out
	27	(Strap) Module Config Bit 0		
		(BK/PK)	26	Alarm Light Out
	25	(Strap) Module Config Bit Gnd		
		(BK)	24	Alarm Power In
Low Level Input	23	(GY/OR)		
		Transient Ground (Solid)	22	
Off Level Input	21	(GY/PK)		
		RTU Power+	20	Not Used
Lead Level Input	19	(GY/RD)		
		RTU Power-	18	Not Used
Lag Level Input	17	(GY/BU)		
		(BK/VL)	16	Motor Starter #1 Out
Lag 2 Level Input	15	(GY/VL)		
		(BK/RD)	14	Motor Starter #2 Out
High Level Input	13	(GY/BN)		
		(BK/YL)	12	Motor Starter #3 Out
Level Input Common	11	(GY/YL)		
		(BK/OR)	10	Motor Starter Power In
Alarm Silence input	9	(WT/PK)		
		(OR)	8	PM Bypass Input
Motor Run Input #1	7	(VL)		
		(BU)	6	Phase C Input
Motor Run Input #2	5	(BN)		
		(RD)	4	Phase B Input
Motor Run Input #3	3	(YL)		
		(PK)	2	Phase A Input
Motor Input Common	1	(WT)		

* The PCM001 module has status LEDs for RTU power, alarm bell, user-defined input, module power, transmit and receive data, phase alarm/calibration, processor fault, six float inputs, pumps on/off.

Radio Interface Module (RIM006)

Notes				Notes
	43	(Strap) Station Address Ground		
		System DC Voltage+ (Bus)	42	
	41	(Strap) Station Address Bit 7		
		System Ground (Bus)	40	
	39	(Strap) Station Address Bit 6		
		Power Down (Bus)	38	
	37	(Strap) Station Address Bit 5		
		Request to Send (Bus)	36	
	35	(Strap) Station Address Bit 4		
		Clear to Send (Bus)	34	
	33	(Strap) Station Address Bit 3		
		Receive Data (Bus)	32	
	31	(Strap) Station Address Bit 2		
		Transmit Data (Bus)	30	
	29	(Strap) Station Address Bit 1		
		PSM Volts+	28	
	27	(Strap) Station Address Bit 0		
		PSM Ground	26	
	25	(Strap) Station Address Bit 8		
		PSM Control	24	
	23	(Strap) Program Strap #3		
		Not Used	22	
	21	(Strap) Program Strap #2		
		(PSM) RTU Power OK	20	
	19	(Strap) Program Strap #1		
		(PSM) Bias OK	18	
Inverted data? Strap to pin 15	17	(Strap) Program Strap #0		
		Motorola Radio Key	16	
Inverted data? Strap to pin 17	15	(Strap) Program Strap Ground		
		Motorola Transmit Data	14	
	13	Ground		
		Radio Transmit Data	12	
	11	Not Used		
		Radio 12.5 VDC+	10	
Black wire to battery-	9	Battery Ground VDC-		
		Radio/Carrier Detect	8	
Red wire to battery+	7	Battery VDC+		
		Radio/RX Data	6	
S/U plate bypass? Strap to pin 3	5	Power Up		
		Radio Key	4	
S/U plate bypass? Strap to pin 5	3	Power Supply Ground		
		Radio Ground	2	
	1	Power Supply Volts+		

* The RIM006 module has status LEDs for power (PWR), receive data (RX), transmit data (TX), on-board hardware fault (FLT), and test mode. Refer to the RIM006 section of this manual beginning on page 27.

Solar Power Module (SPM002)

Notes				Notes
	43	Not Used		
			System V+	42
	41	Not Used		
			System Ground	40
	39	Not Used		
			Not Used	38
	37	Solar Panel 1 In +		
			Solar Panel 2 In +	36
	35	Solar Panel 1 In -		
			Solar Panel 2 In -	34
			=KEY=	
	33	Battery Out +		
			Battery Out +	32
	31	Battery Out -		
			Battery Out -	30
	29	Not Used		
			12 VDC Bias (+)	28
	27	Power Supply V+		
			12 VDC Bias (+)	26
	25	Power Supply Common		
			12 VDC Bias (+)	24
	23	Not Used		
			12 VDC Bias (+)	22
			=KEY=	(Key for 50W and 100W Only)
	21	RTU Power OK		
			12 VDC Bias (-)	20
	19	12 VDC Bias OK		
			12 VDC Bias (-)	18
	17	Not Used		
			12 VDC Bias (-)	16
	15	Not Used		
			12 VDC Bias (-)	14
	13	Battery In +		
			Transient Ground	12
	11	Battery In -		
			Not Used	10
			=KEY=	
	9	Not Used		
			Not Used	8
	7	Not Used		
			Not Used	6
	5	Not Used		
			Not Used	4
	3	Not Used		
			Safety Ground	2
	1	Not Used		

* The SPM002 module has status LEDs for power (PWR_OK) and DC bias (BIAS_OK). Refer to the SPM002 section of this manual beginning on page 29.

Telemetry Interface Module (TIM007)

Notes				Notes
	43	(Strap) Address Ground		
		System DC V+ (RIM)	42	
	41	(Strap) Address Bit 7		
		System Gnd (RIM)	40	
	39	(Strap) Address Bit 6		
		Power Down (RIM)	38	
	37	(Strap) Address Bit 5		
		RTS (RIM)	36	
	35	(Strap) Address Bit 4		
		CTS (RIM)	34	
	33	(Strap) Address Bit 3		
		RX Data (RIM)	32	
	31	(Strap) Address Bit 2		
		TX Data (RIM)	30	
	29	(Strap) Address Bit 1		
		P.S. V+ (PSM)	28	
	27	(Strap) Address Bit 0		
		P.S. Gnd (PSM)	26	
	25	(Strap) Address Bit 8		
		P.S. Control (PSM)	24	
	23	(Strap) 9600 Bus		
		Not Used	22	
	21	(Strap) Future Cfg Bit		
		RTU Power OK (PSM)	20	
	19	(Strap) Swap		
		Bias OK (PSM)	18	
	17	(Strap) Invert		
		Modbus A 485	16	
	15	(Strap) Cfg Gnd		
		Modbus B 485	14	
	13	Not Used		
		Radio TXD 232	12	
	11	Not Used		
		Modbus TXD 232	10	
	9	Battery Gnd		
		Modbus RXD 232	8	
	7	Battery V+		
		Radio RXD 232	6	
	5	Power Up		
		Not Used	4	
	3	P.S. Gnd		
		Radio/Modbus Gnd 232	2	
	1	P.S. V+		

* The TIM007 module has status LEDs for transmit data (TX), receive data (RX), power, and CPU fault. Refer to the TIM007 section of this manual beginning on page 31 and to the *TIM007 Installation and Operation Manual* (available for download from www.DataFlowSys.com).

Telemetry Control UNIT (TCU001)

Refer to the TCU section of this manual beginning on page 30 and to the *TAC Pack TCU Installation & Operation Manual* (available for download from www.DataFlowSys.com).

Wire Color Abbreviation Chart

Abbreviation	Color
BK	Black
BN	Brown
BU	Blue
GN	Green
GY	Grey
OR	Orange
PK	Pink
RD	Red
VL	Violet
WH	White
YL	Yellow

Notes

4
411. *See* dial-in access

9
911. *See* alarms, dial out for

A

ACM002, 12, 15
 pin descriptions, 63
 See also analog control point, wiring.
 addressing modules, 53
 alarms, dial out for, 7
 telephone requirements, 7
 aligning the antenna, 60
 AMM002, 12, 16
 pin descriptions, 64
 See also analog monitor point, wiring; digital monitor point, wiring.
 Analog Control Module. *See* ACM002
 analog control point, wiring, 52
 analog inputs, 13
 Analog Monitor Module. *See* AMM002
 analog monitor point
 wiring, 49–51
 0-20mA current loop with AMM-supplied power, 51
 0-20mA current loop with transducer-supplied power, 50
 0-5 V voltage source, 51
 analog outputs, 13
 antenna
 aligning, 60
 central site installation, 40
 remote site installation, 43–45

B

BEM001, 11, 17
 pin descriptions, 65
 wiring, 54–56
 bloodborne pathogens, 37
 Bus Extender Module. *See* BEM001

C

cellular RTU, 4, 8
 central site, 5–7, 39–41
 alarm dial out, 7
 antenna, installing, 40
 central terminal unit (CTU)
 installing, 40

 power supply for, 41
 communication methods, 5
 dial out for alarms, 7
 dial-in access, 6–7
 human machine interface (HMI), 6
 Hyper SCADA Server (HSS), 5
 connecting to CTU, 40
 installing, 39
 master radio, 7
 remote maintenance, 6–7
 RTU configuration, 60–61
 site survey, 34–35
 workstation, installing, 39
 Central Terminal Unit. *See* CTU
 communication
 methods, 3–4
 cellular, 4
 Ethernet, 4
 radio, 3–4
 modules for, 11
 protocols, 4
 conduit, installing at remote site, 45
 confined space, 36
 control panel
 installing at remote site, 45
 wiring, 58
 control point. *See* digital control point; analog control point
 controlling I/O. *See* I/O, monitoring and controlling CTU, 7
 connecting to Hyper SCADA Server (HSS), 40–41
 installing, 40
 power supply for, 41

D

DCM003, 11, 18
 pin descriptions
 DCM003-1, 66
 DCM003-2, 67
 DCM003-3, 68
 DCM003-4, 69
 DCM003-5, 70
 DCM003-6, 71
 See also digital control point, wiring; digital monitor point, wiring; pulse accumulator point, wiring.
 Derivative Fractional Protocol. *See* DFP
 DFP, 4
 dial out. *See* alarms, dial out for
 dial-in access, 6–7
 telephone requirements, 7
 digipeating, 4
 Digital Control Module. *See* DCM003

digital control point, wiring, 48
 digital control test card, 59
 digital inputs, 12
 Digital Monitor Module. *See* DMM002
 digital monitor point
 wiring (10-30 volt), 47
 wiring (31-300 volt), 47
 digital monitor test card, 59
 digital outputs, 12
 DMM002, 11, 20
 pin descriptions, 72
 See also digital monitor point, wiring; pulse accumulator point, wiring.

E

enclosure for RTU, 9
 Ethernet RTU, 4, 8

F

Fiber Interface Module. *See* FIM001
 FIM001, 21
 pin descriptions, 73
 frequencies, 33–34
 licensing, 34
 function modules, 11–31
 ACM002, 15
 addressing, 53
 AMM002, 15, 16
 analog I/O, 12
 BEM001, 17
 communication, 11
 DCM003, 18
 digital I/O, 11
 DMM002, 20
 FIM001, 21
 installing, 59
 network, 11
 overview, 11
 pin descriptions of. *See* pin descriptions
 PLC001, 22–30
 PLC033, 22–30
 power, 11
 programmable, 12
 PSM003, 22
 radio, 11
 RIM006, 27
 SPM002, 29
 TCU001, 30
 TIM007, 31
 See also I/O.

H

HMI, 2, 6
 HT3 Mobile, 6
 HT3 SCADA software, 2, 5, 49

human machine interface. *See* HMI
 Hyper SCADA Server, 5
 connecting to CTU, 40–41
 installing, 39

I

I/O
 analog inputs, 13
 analog outputs, 13
 digital inputs, 12
 digital outputs, 12
 monitoring and controlling, 12–13
 wiring. *See* wiring
 See also pin descriptions.
 inputs, analog. *See* analog inputs
 inputs, digital. *See* digital inputs
 installing
 central site. *See* central site, installing
 function modules, 59
 remote site. *See* remote site, installing
 TAC II SCADA system. *See* TAC II SCADA system, planning

L

licensing of radio frequencies, 34
 lockout procedures, 36

M

master radio, 7
 MBP. *See* modular backplane
 mobile phone. *See* HT3 Mobile
 Modbus ASCII, 4
 Modbus RTU, 4
 Modbus TCP/IP, 4
 modular backplane, 9
 modules. *See* function modules
 monitor point. *See* digital monitor point; analog monitor point
 monitoring I/O. *See* I/O, monitoring and controlling
 MySQL, 5

N

NetDFP, 4
 network communication
 See also Ethernet RTU; FIM001.
 Network Derivative Fractional Protocol. *See* NetDFP
 network interface module. *See* FIM001

O

operator workstations, 6
 OSHA, 36
 outputs, analog. *See* analog outputs
 outputs, digital. *See* digital outputs

P

PCM001, pin descriptions, 77
 pin descriptions of function modules, 63–82
 ACM002, 63
 AMM002, 64
 BEM001, 65
 DCM003-1, 66
 DCM003-2, 67
 DCM003-3, 68
 DCM003-4, 69
 DCM003-5, 70
 DCM003-6, 71
 DMM002, 72
 FIM001, 73
 PCM001, 77
 PLC001, 75
 PLC033, 76
 PSM003, 74
 RIM006, 78
 SPM002, 79
 TCU001, 81
 TIM007, 80
 planning a TAC II SCADA system. *See* TAC II SCADA system, planning
 PLC, 6, 12, 22–30
 See also PLC001; PLC033; TCU001; RDP180.
 PLC001, 12, 23
 pin descriptions, 75
 PLC033, 12, 25
 pin descriptions, 76
 power supply for CTU, 41
 Power Supply Module. *See* PSM003
 power, wiring, 46
 programmable device. *See* PLC; RDP180; TCU001
 programmable logic controller. *See* PLC
 protocol. *See* communication protocols
 PSM003, 22
 pin descriptions, 74
 pulse accumulator point, wiring, 49
 Pump Control Module. *See* PCM001; *See also* TCU001
 pump controller. *See* TCU001

R

radio
 communication, 3
 digi-peating, 4
 RIM006, 3
 TIM007, 3
 frequencies, 33–34
 licensing, 34
 testing VSWR, 60
 See also RIM006; TIM007.
 Radio Interface Module. *See* RIM006
 radio, master, 7
 RDP180, 12
 remote maintenance of SCADA system, 6–7

remote site
 antenna, installing, 43–45
 conduit, installing, 45
 control panel, installing, 45
 CTU, configuring into, 60–61
 final check of installation, 60
 installing, 43–58
 site survey, 35
 wiring. *See* wiring
 remote terminal unit. *See* RTU
 RIM006, 27
 pin descriptions, 78
 RTU, 8–9
 cellular-based, 4, 8
 enclosure, 9
 Ethernet-based, 8
 modular backplane, 9
 radio-based, 8
 wiring, 53
 See also remote site.

S

safety issues, 36–37
 SCADA system
 overview, 1–2
 See also TAC II SCADA system.
 serial tunneling. *See* FIM001
 site survey, 34–35
 central site, 34–35
 remote site, 35
 smart phone. *See* HT3 Mobile
 Solar Power Module. *See* SPM002
 SPM002, 11, 29
 pin descriptions, 79
 wiring, 57
 survey. *See* site survey

T

TAC II protocol, 4
 TAC II SCADA system
 cellular network communication, 4
 communication methods and protocols, 3
 Ethernet network communication, 4
 HT3 SCADA software, 2
 human machine interface (HMI), 2
 planning, 33–37
 frequencies, 33–34
 licensing, 34
 OSHA, 36–37
 safety issues, 36–37
 radio communication, 3
 RIM006, 3
 TIM007, 3
 remote maintenance, 6–7
 typical, 2
 tagout procedures, 36

TCU001, *12, 30*
pin descriptions, *81*
Telemetry Control Unit. *See* TCU001
Telemetry Interface Module. *See* TIM007
telephone requirements for dial-in and dial-out access, *7*
testing
VSWR, *60*
wiring, *59*
digital control test card, *59*
digital monitor test card, *59*
TIM007, *11, 31*
pin descriptions, *80*
tunneling, serial. *See* FIM001

V

VSWR, testing, *60*

W

wiring, *46–58*
analog control point, *52*

analog monitor point, *49–51*
0-20mA current loop with AMM-supplied power, *51*
0-20mA current loop with transducer-supplied
power, *50*
0-5 V voltage source, *51*
BEM001, *54–56*
control panel, *58*
digital control point, *48*
digital monitor point (10-30 volt), *47*
digital monitor point (31-300 volt), *47*
power, *46*
pulse accumulator point, *49*
RTU, *53*
SPM002, *57*
testing, *59*
digital control test card, *59*
digital monitor test card, *59*
wire color abbreviation chart, *81*
workstations, *6*
installing, *39*



Data Flow Systems, Inc.
605 N. John Rodes Blvd., Melbourne, FL 32934
Phone 321-259-5009 • Fax 321-259-4006
www.DataFlowSys.com